

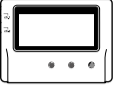













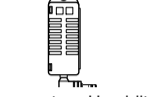



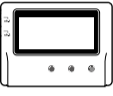

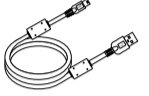
# TR-7wb/nw Series Thermo Recorder Please Read First

## Package Contents

<b>TR-71wb / TR-71nw</b>	<b>Temperature 2ch</b>
 Data Logger	 Temperature Sensor TR-0106 x 2
 AA Alkaline Battery (LR6) x 2	 USB Mini-B Cable (US-15C)
 Manual Set (Warranty Included)	 Registration Code Label
<b>TR-72wb / TR-72nw</b>	<b>Temperature 1ch, Humidity 1ch</b>
 Data Logger	 Temperature-Humidity Sensor THA-3001
 AA Alkaline Battery (LR6) x 2	 USB Mini-B Cable (US-15C)
 Manual Set (Warranty Included)	 Registration Code Label
<b>TR-72wb-S / TR-72nw-S</b>	<b>Temperature 1ch, Humidity 1ch (High-Precision Type)</b>
 Data Logger	 High Precision Temperature-Humidity Sensor SHA-3151
 AA Alkaline Battery (LR6) x 2	 USB Mini-B Cable (US-15C)
 Manual Set (Warranty Included)	 Registration Code Label
<b>TR-75wb / TR-75nw</b>	<b>Thermocouple (K, J, T, E, S, R) Temperature 2ch</b>
 Data Logger	 AA Alkaline Battery (LR6) x 2
 USB Mini-B Cable (US-15C)	 Manual Set (Warranty Included)
 Registration Code Label	

\* Please prepare a thermocouple separately. T&D does not handle the sale of thermocouple sensors.

## GettingLogger Ready for Installation

### Battery Installation & Sensor Connection

#### Battery

Make sure to use new batteries (including for replacement) and insert in the correct direction.

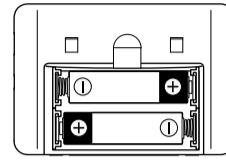

#### TR-71wb / TR-71nw

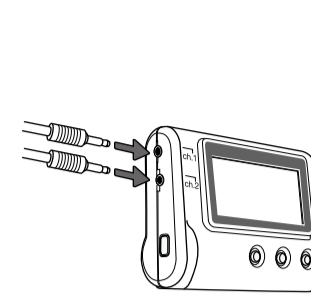

#### TR-72wb / TR-72nw TR-72wf-S / 72nw-S

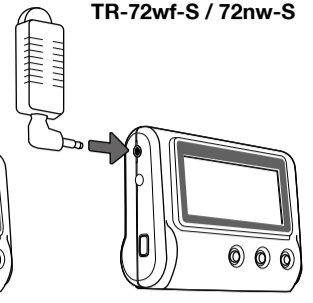

### About TR-71wb / TR-71nw Internal Sensor

Channel 1 has an internal temperature sensor. When an external sensor is not connected, the internal sensor will be used.

### About TR-75wb / TR-75nw Input Terminal

When connecting thermocouple wires to the input terminal, make sure that the positive and negative connections are in the proper order. If the polarity is incorrect, changes in temperature will be reversed (when the real temperature increases, the measured temperature will decrease).

#### Wiring Connections

Connect and disconnect the thermocouple wire from the hole while pressing the input terminal button with a screwdriver or other such tool. Do not try to pull out the wire without pressing the button.

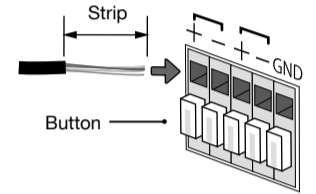

#### Compatible Wires

Single wire:  $\varnothing$  0.32 to  $\varnothing$  0.65 mm (AWG 28-22)  
Twisted wire: 0.08 to 0.32 mm<sup>2</sup> (AWG 28-22)  
Diameter: 0.12 mm or more  
Strip length: 9 to 10 mm

#### Using GND

If measurements are unstable while using external power (USB or PoE), connect to the GND terminal.

### TR-71wb / TR-71nw TR-72wb / TR-72nw TR-72wf-S / 72nw-S

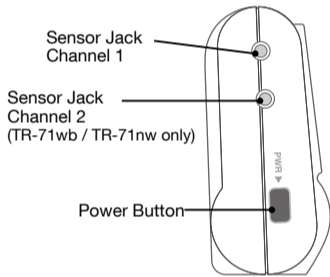

### TR-75wb / TR-75nw

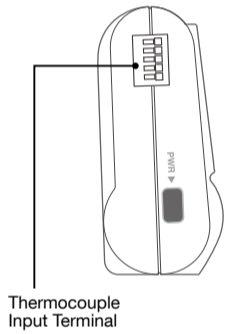

### TR-71wb / 72wb / 75wb TR-71nw / 72nw / 75nw (Wireless LAN) (Wired LAN)

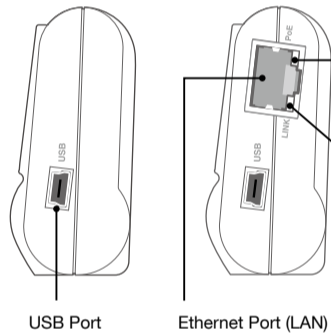
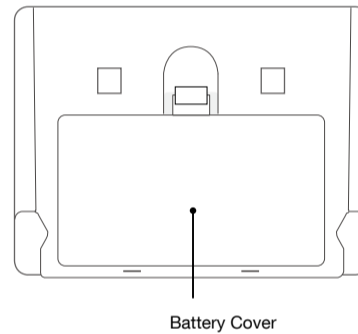



- » See the Introductory Manual for how to set and check thermocouple sensor type for TR-75wb / TR-75nw.
- » The Introductory Manual also explains operations using the operation buttons.

## Safety Precautions and Instructions



The following items should be strictly obeyed for the safe usage of this product, and for protecting yourself and other people from bodily harm and/or damage to property.

### Explanation of Symbols









#### <Warning Symbols>

 <b>DANGER</b>	These entries are actions that absolutely under no circumstance should be taken. The taking of such an action may cause serious personal physical damage or death.
 <b>CAUTION</b>	These entries are actions that if taken may lead to physical injury or damage to persons or things.

#### <Picture Symbols>

 Denotes an important warning or caution.	 Denotes a forbidden action.	 Denotes an action that should not be carried out.
--	---	---

### **DANGER** To Prevent Serious Accidents

-  Do not disassemble, repair or modify the unit and/or accessories.
-  Do not use the unit in any environment that is exposed to chemicals and harmful gases. Doing so may cause corrosion and/or other danger to the unit. Also, coming in contact with hazardous substances may cause bodily harm to the user or people nearby.
-  This product is not water resistant. If water or a foreign object enters the case, immediately remove batteries and stop using it.
-  Do not touch the unit or AC adaptor during thunder and lightning, as this may cause electrocution.
-  Do not handle the unit, remove batteries or cables with wet hands.
-  This product has been designed for private and/or industrial use only. It should not be used in situations where strict safety precautions are necessary such as with medical equipment, or in systems directly or indirectly connected with human life or well-being.
-  Do not drop or expose the unit to a strong impact.
-  Do not cut or process the cords for the communication cables. Also, do not twist, pull on or swing any of the cords.
-  To prevent damage to the unit from static electricity, remove static electricity from your body by touching metal around you (such as a door knob and window frame) before touching the unit.

 Place and store the unit and accessories out of the reach of children.

 We are not responsible for any damage, malfunction or trouble, whether direct or indirect, caused by the use of our product.

 Do not use any battery, sensor, or cable other than those specified by T&D Corporation.

 Do not put anything on top of the cable or the unit. This may cause overheating.

 Do not disconnect the USB cable during USB communication. Doing so may cause adverse effects to the unit and/or PC.

 Make sure that sensor and cable plugs are all inserted fully, so as not to cause an improper connection. Also, when unplugging the cable from the unit, do not pull the cord, but hold the connector to disconnect.

 If the unit produces heat, emits smoke or a strange smell, or makes unusual noise, immediately remove the batteries and stop using it. Also, unplug the unit from the PC.

 If the unit is not to be used for a long period of time, remove batteries. Leaving batteries inside the unit may cause battery leakage and malfunction. Install new batteries when starting or re-starting to use a unit.

 For TR-75wb / TR-75nw: Ch.1 and Ch.2 terminals are NOT electricaly isolated from each other. Do not attach non-isolated thermocouple sensors to objects connected to a live voltage. This may cause a short circuit or an electrical shock.

### **CAUTION** Do not place or store in the following areas:

- » Areas exposed to direct sunlight
- » Areas subject to direct flames or heaters, as well as areas in which hot air accumulates and creates extremely high temperatures
- » Areas exposed to static electricity
- » Areas exposed to strong magnetic fields
- » Areas exposed to water leakage
- » Areas subject to condensation or wet areas
- » Areas exposed to excessive vibration
- » Areas exposed to excessive smoke, dust or dirt.

### **CAUTION** Other Precautions

- » Use the unit in the specified operating environment. Do not use it for any purpose other than for which it was designed.
- » Condensation may occur inside the case when a unit is moved from one environment to another where there is a great difference in temperature.
- » Do not use the unit in wet areas or places exposed to water such as bathroom.

- » When connecting the unit to your PC, make sure to follow all warnings and directions from your computer manufacturer.
- » We shall not guarantee the unit's operation if it has been connected to a PC using a USB hub or a USB extension cable.
- » Do not insert any foreign objects into any of the units' jacks.
- » If the unit gets dirty, wipe it with a clean cloth.
- » Make sure to remove dust and dirt from plugs of any cables.
- » Battery terminals may provide insufficient contact due to age or vibration. This may lead to data loss.
- » Please note that this document has been written based on the presupposition that details about contracts with an Internet provider, specific network environments and the set-up of any other necessary equipment to enable network connection has already been taken care of by the User and that connection has been confirmed as workable. T&D Corporation shall not be responsible for any damages which a contractor, a user or a third party may suffer, whether direct or indirect, due to the inability to communicate or use communication devices.

### **CAUTION** Notices about Sensors

- » Do not connect any sensor to the unit other than those specified by T&D Corporation.
- » Make sure to use sensors within the measurement range indicated in the specifications for that sensor.
- » Do not connect the sensor to any data logger other than those specified by T&D Corporation.
- » Do not expose the sensor to a strong impact. This may adversely affect measurement accuracy and cause damage or malfunction.
- » When the sensor is not to be used for a long period of time, please store it at normal temperature and humidity.
- » The included sensor is not water resistant. If the sensor gets wet, immediately remove the sensor from the unit and wipe it with a clean cloth as soon as possible. Then allow the sensor to dry in normal room temperature before using it again.
- » Do not use the sensor on the human body.

#### Temperature-Humidity Sensor

- » If extremely severe temperature changes occur, it may result in large errors in humidity measurement. Once the sensor's temperature becomes stable, the measurements will return to normal.
- » The temperature-humidity sensors will with normal use experience losses in precision and sensitivity over time due to degradation. If the sensor is being used in an unsuitable environment (smoky or dusty places) it may be necessary to change the sensor sooner.
- » When using the sensor in an environment where the humidity is under 30%RH, the measurements may sometimes fluctuate. This is not abnormal.
- » Do not expose to condensation, dampness, corrosive gases, or organic solvents.

#### Thermocouple Sensors

- » We do not handle the sale of Thermocouple sensors. Please prepare a commercially available sensor.

## TR-7wb/nw Series - Specifications

	TR-71wb / TR-71nw	TR-72wb / TR-72nw		TR-72wb-S / TR-72nw-S		TR-75wb / TR-75nw
Measurement Channels	Temperature 2ch	Temperature 1ch,	Humidity 1ch	Temperature 1ch,	Humidity 1ch	Temperature 2ch
Sensor	Thermistor	Thermistor	Polymer Resistance	Thermistor	Polymer Resistance	Thermocouple: Type K, J, T, E, S, R (*1)
Measurement Units	°C, °F	°C, °F	%RH	°C, °F	%RH	°C, °F
Measurement Range	Internal Sensor	-10 to 60°C (*2)	-	-	-	-
	External Sensor	-40 to 110°C (Supplied Sensor) -60 to 155°C (Optional Sensor: Fluoropolymer Coated Type)	0 to 55°C	10 to 95 %RH	-25 to 70°C	0 to 99 %RH (*3)
Accuracy	Avg. ±0.3°C at -20 to 80°C Avg. ±0.5°C at -40 to -20°C, 80 to 110°C	±0.5°C	±5 %RH at 25°C, 50 %RH	±0.3°C at 10 to 40°C ±0.5°C at all other temperatures	±2.5 %RH at 15 to 35°C, 30 to 80 %RH	Thermocouple Measurement (Sensor inaccuracies not included) Type K, J, T, E : ±(0.5°C + 0.3 % of reading) at -100°C or above Type S, R : ±(1.5°C + 0.3 % of reading) at 100°C or above Cold Junction Compensation ±0.5°C at 10 to 40°C ±0.8°C other temperatures within the operating environment of the logger
Measurement Resolution	0.1°C	0.1°C	1 %RH	0.1°C	0.1 %RH	Type K, J, T, E: 0.1°C, Type S, R: Approx. 0.2°C
Responsiveness	Thermal Time Constant: Approx. 75 sec. Response Time (90%): Approx. 190 sec.	Response Time (90%): Approx. 7 min.		Response Time (90%): Approx. 7 min.		-

Logging Capacity	8,000 data sets (One data set consists of readings for all channels in that type of unit.)
Recording Interval	Select from 15 choices: 1, 2, 5, 10, 15, 20, 30 sec. or 1, 2, 5, 10, 15, 20, 30, 60 min.
Recording Mode	Endless (Overwrite oldest data when capacity is full) / One Time (Stop recording when capacity is full)
Auto-upload Interval	Select from 15 choices: OFF (No auto-upload), 1, 2, 5, 10, 15, 20, 30 min. or 1, 2, 3, 4, 6, 12, 24 hrs.
Communication Interfaces	TR-71wb / 72wb / 75wb: Wireless LAN Communication Standard : IEEE 802.11b/g/n Security (*4): WEP (64bit/128bit), WPA-PSK(TKIP), WPA2-PSK(AES) WPS 2.0 : Push Button Configuration Protocol : HTTP(*5), DHCP, DNS TR-71wb / 72wb / 75wb: Bluetooth Communication Bluetooth 4.2 (Bluetooth low energy) TR-71nw / TR-72nw: Wired LAN Communication 100BASE-TX/10BASE-T (RJ45 Connector) Protocol : HTTP(*5), DHCP, DNS USB Communication USB 2.0 (Mini-B connector)
Power (*6)	Battery: AA Alkaline x 2, AA Ni-MH x 2 External: USB Bus 5V 200mA, AC Adaptor AD-05A2 or AD-05C2, PoE IEEE 802.3af (TR-71nw / 72nw / 75nw only)
Battery Life (*7)	TR-71wb/TR-72wb: Approx. 10 days to 15 months (*8) TR-71nw/TR-72nw: Approx. 10 days to 1.5 years (*9) TR-75wb: Approx. 10 days to 1 year (*8) TR-75nw: Approx. 10 days to 1 year (*9)
Dimensions	H 58 mm x W 78 mm x D 26 mm
Weight	Approx. 55 g
Operating Environment	Temperature -10 to 60°C (*10), Humidity 90 %RH or less (no condensation)
Software	TR-7wb/nw for Windows, T&D Graph, T&D Data Server, T&D Thermo
Compatible OS (*11)	TR-7wb/nw for Windows / T&D Graph / T&D Data Server (For PC) Microsoft Windows 10 32 / 64 bit Microsoft Windows 8 32 / 64 bit Microsoft Windows 7 32 / 64 bit T&D Thermo (For Mobile Devices) Android OS, iOS (For the compatible versions, please refer to our website.)
Display Languages (*12)	English

\*1: Compatible wire sizes are as follows. Single Wire : Ø 0.32 to Ø0.65 mm (AWG 28 - 22), Twisted Wire : 0.08 to 0.32 mm<sup>2</sup> (AWG 28 - 22), Ø 0.12 mm or more in diameter, Stripping Length : 9 to 10 mm

\*2: When Auto Upload is used frequently, the measurement of the internal sensor may rise by around 0.3°C .

When using external power, the data logger itself generates heat and the internal sensor will report a temperature much higher than ambient; we recommend using an external temperature sensor in this case.

\*3: When continually used in environments with temperatures above 60°C, accuracy of humidity measurements will decrease over time. Also, humidity cannot be measured at temperatures below -20°C.

\*4: If you wish to use the WPS feature, set the security type of the wireless LAN access point to "WPA2-PSK(AES)" or "None".

\*5: HTTP client. Proxy supported.

\*6: When using external power, the internal temperature of the logger rises.

\*7: Battery life is highly dependant on the Auto-upload interval; at 1 min will give 10 days of usage, and at 12 hours or more will yield the maximum lifetime. Other influential factors include LAN environment, ambient temperature, recording interval, and battery performance. All estimates are based on operations carried out with a new battery and are in no way a guarantee of actual battery life.

\*8: Shows the estimated battery life with Bluetooth and Auto-Upload ON. It will be 1.2 times longer with Bluetooth OFF.

\*9: Shows the estimated battery life with Auto-Upload ON.

\*10: -10 to 45°C when using external power (TR-71nw / 72nw / 75nw only).

\*11: For installation, it is necessary to have Administrator (Computer Administrator) rights.

\*12: We recommend using an operating system in the same language as the display language. Operation in different languages is not guaranteed.

The specifications listed above are subject to change without notice.

### Important Notices and Disclaimers

In order to properly use this product, please carefully read all documents that accompany the product before using.

» All rights of the attached documents belong to T&D Corporation. It is prohibited to use, duplicate and/or arrange a part or whole of the attached documents without the permission of T&D Corporation.

» Microsoft and Windows are registered trademarks of Microsoft Corporation in the United States and/or other countries.

» Google, Android, and Google Play are trademarks or registered trademarks of Google Inc.

» Apple and App Store are trademarks or registered trademarks of Apple, Inc. in the U.S. and other countries.

» The Bluetooth® word mark and logos are registered trademarks owned by Bluetooth SIG, Inc. and any use of such marks by T&D Corporation is under license.

» All registered trademarks, company names, product names and logos mentioned herein or for products being used are the property of T&D Corporation or of their respective owners.

» Specifications, design and other contents outlined in the attached documents are subject to change without notice.

» Please follow the safety precautions outlined in the attached documents carefully. We cannot guarantee nor are we responsible for safety if this product is used in any manner other than was intended.

» On-screen messages in the attached documents may vary slightly from the actual messages.

» Please notify the shop where you purchased this product or T&D Corporation of any mistakes, errors or unclear explanations in the attached documents.

» T&D Corporation accepts no responsibility for any damage or loss of income caused by the use of our product.

» Accompanying documents cannot be reissued, so please keep them in a safe place.

» Please read the warranty and provisions for free repair carefully.

### For product information or questions contact us at:

## T&D Corporation

For product inquiries, please contact your local distributor. Visit T&D Website for the distributors list.

If you can not find a distributor in your area, please contact our main office in Japan or one of our branch offices in Europe or America.

<https://www.tandd.com/purchasing/index.html>

2019.02 16508120004 (1st Edition)

### TR-7wb/nw Series Warranty

Product under Warranty (Excluding Accessories)	<input type="checkbox"/> TR-71wb	<input type="checkbox"/> TR-72wb	<input type="checkbox"/> TR-72wb-S	<input type="checkbox"/> TR-75wb
	<input type="checkbox"/> TR-71nw	<input type="checkbox"/> TR-72nw	<input type="checkbox"/> TR-72nw-S	<input type="checkbox"/> TR-75nw
Warranty Period	1 year from date of purchase			
Date of Purchase				
Customer's name				
Address				
Phone No.				
Distributor's name				
Address				
Phone No.				
Object of Repair	Main Unit (excluding sensors and any other options.)			
Method of Repair	Send in for Repair			

#### Provisions for Free Repair

- If the unit does not work properly despite the fact that the customer used it properly and in line with the manual, the Unit shall be repaired free of charge through the distributor which sold the unit.
- If the customer requests free repair because of trouble within the warranty period, bring or send the unit along with the warranty to the distributor.
- If you have moved after purchasing, or there are difficulties contacting the distributor from which you purchased the unit, please contact T&D directly for service.
- Free repair is not available in the following cases even though it is within the warranty period:
  - Trouble or damage was caused by careless operation, natural disaster, fire, public pollution, use of a power source other than specified, or external factors such as intrusion of insects.
  - If repair, adjustment, disassembly or modification of the unit has been carried out by a person other than a T&D authorized engineer.
  - Trouble or damage was caused by transportation, movement or dropping of the unit after purchase.
  - Failure to submit the warranty or failure to fill in all items required in the warranty.
- The warranty cannot be reissued.

This warranty only promises customers free repair within the period and conditions clarified in this warranty. Therefore, the customer's legal rights will not be limited by this warranty. For further information on repair and other service questions after the termination of the warranty period, contact your distributor.

**T&D CORPORATION**