

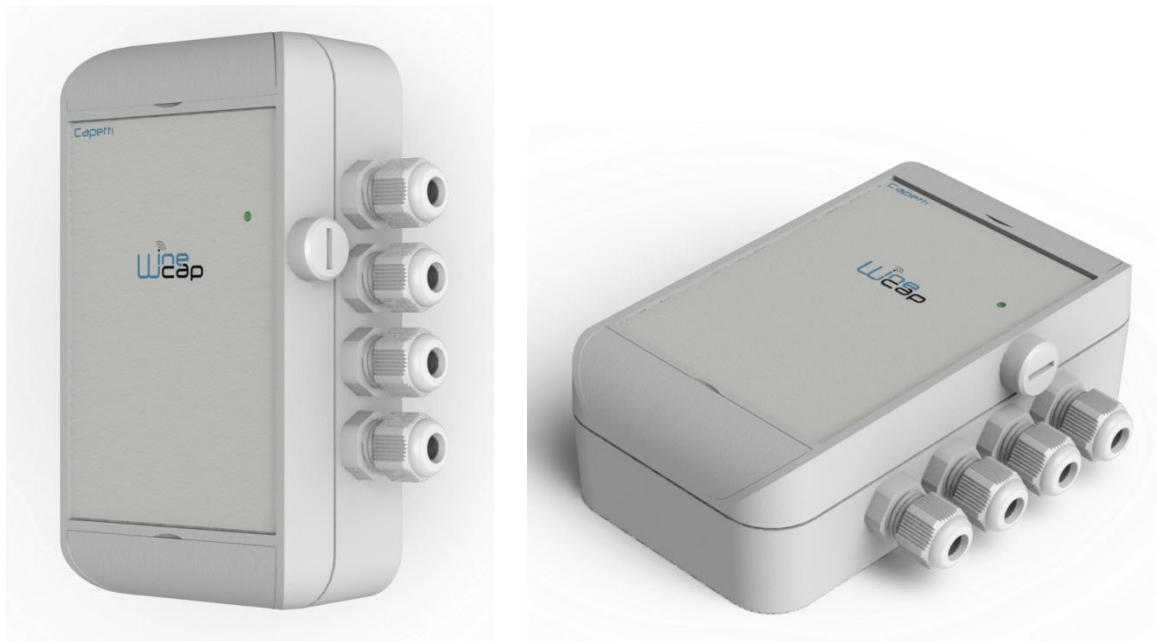

**1. Description.**

The **WSD12PS-4AIM4** is a four analog inputs **datalogger** designed for voltage measurement ( $0\div 5Vdc$ ,  $0\div 10Vdc$ ,  $0\div 25Vdc$ ) or current ( $0\div 25mA$ ) selectable using jumpers, capable of powering external transducers with a 12Vdc or 24Vdc power supply (up to 100mA). Measurements acquired are expressed in percentage of full scale.



Picture 1 - Product Image

## 2. Channel description.

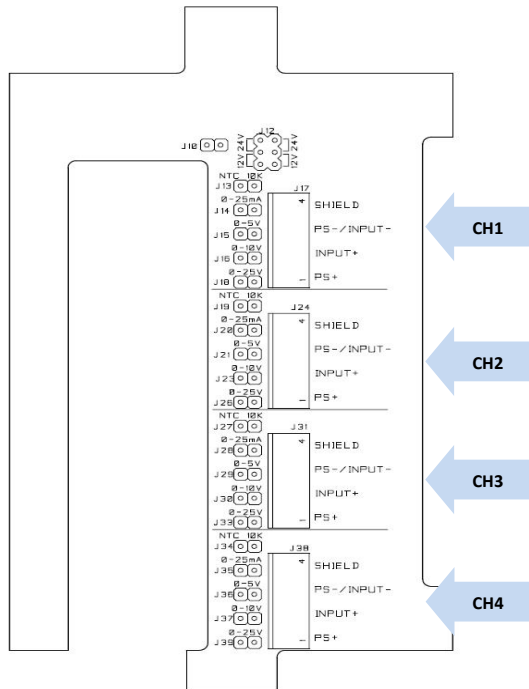

**PS+:** Polo positivo della tensione generata dal **datalogger** per alimentare i trasduttori. 12Vdc o 24Vdc @ 100mA selezionabile tramite **J12**.

**INPUT +:** Ingresso segnale. 0÷25mA, 0÷5Vdc, 0÷10Vdc, 0÷25Vdc. Fondoscala selezionabile tramite i jumper di scala.



**PS-/INPUT-:** Polo negativo della tensione generata dal **datalogger**. Riferimento negativo per segnale di ingresso.

**SHIELD:** connessione schermo cavo

Picture 2 - Channel description

## 3. Selecting the generated power supply.

The **datalogger** supplies for 1 second a DC voltage on **PS+** pin of the terminal block. The value of the DC voltage can be selected using **J12** (**Picture 3 - Jumper positions**):

	DC voltage generated for 1 second: 24Vdc @ 100mA
	DC voltage generated for 1 second: 12Vdc @ 100mA

Picture 3 - Jumper positions

Removing jumper **J10** (**Picture 2 - Channel description**), voltage generation on pin **PS+** of the terminal block is disabled. This situation may be useful in case the DC voltage is not necessary. Consequently the battery life is increased.



#### 4. Full-scale setting.

The measurement's full-scale selection, is done positioning a jumper on the proper strip:

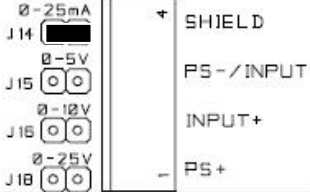
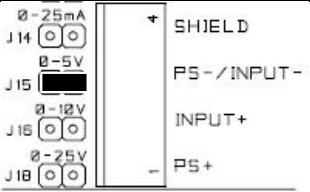
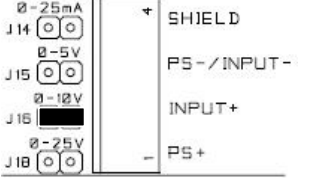
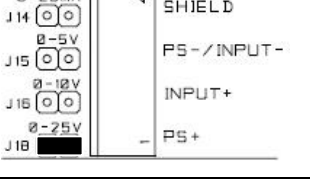
	<p>SHIELD</p> <p>PS - / INPUT -</p> <p>INPUT +</p> <p>PS +</p>	<p><b>0÷25mA input</b></p>
	<p>SHIELD</p> <p>PS - / INPUT -</p> <p>INPUT +</p> <p>PS +</p>	<p><b>0÷5Vdc input</b></p>
	<p>SHIELD</p> <p>PS - / INPUT -</p> <p>INPUT +</p> <p>PS +</p>	<p><b>0÷10Vdc input</b></p>
	<p>SHIELD</p> <p>PS - / INPUT -</p> <p>INPUT +</p> <p>PS +</p>	<p><b>0÷25Vdc input</b></p>

Picture 4 - Full-scale setup

The measurement acquired is displayed as percentage of the selected full-scale.

#### 5. Measurement's scale impedance.

Input	Input's impedance
0÷25mA	100Ω
0÷5V	24KΩ
0÷10V	16KΩ
0÷25V	13,333KΩ

Picture 5 - Input's impedance

## 6. Device preset and use mode.

### a. Wireless Mode:

No setup operation is needed. Typically the system is configured from factory so the device is already associated to the system **basestation**. The device is in *STANDBY* mode (refer to [Picture 9 - Status table - Radio signal quality](#)) for which is necessary to start it with the *TEST* command (refer to [Installation procedure](#)).

Otherwise, in case the device is in *FACTORY RESET* mode (refer to [Picture 9 - Status table - Radio signal quality](#)), that means it's ready for connecting to an existing system, in order to associate it, make reference to the "[WineCap System - User Manual R29](#)" software manual. Is necessary to use the "[WineCapManager](#)" software on the PC connected to the **basestation** that will be coupled with the device.

### b. USB Logger Mode:

For this operation mode, stand-alone with data downloads through USB, the connection with the PC and the "[WineCapManager](#)" running on it is necessary in order to modify the device 's operation mode. The sampling interval must be set with the device in "*STAND-ALONE*" (refer to [Stand-alone USB datalogger installation](#).) mode and automatically, the device 's clock is aligned with the PC's clock, in order to assure the temporal reference of the sample.

Sampling operations start may be selected disconnecting the USB cable or giving the proper command with the magnetic key. (refer to [Stand-alone USB datalogger installation](#).) More details on device 's connection/disconnection through the USB cable are available on the [WineCap System - User Manual R29](#) manual.

### c. On field transition from USB to Wireless datalogger:

This transition is practicable in field, during the sampling period, using the wireless network association command. When the association is done, the **datalogger** becomes a wireless **datalogger** and, besides sending new measures to the **basestation**, starts a download process towards the same **basestation** of the measures acquired during the stand alone period (refer to [Picture 10 - Stand-alone datalogger status](#)).

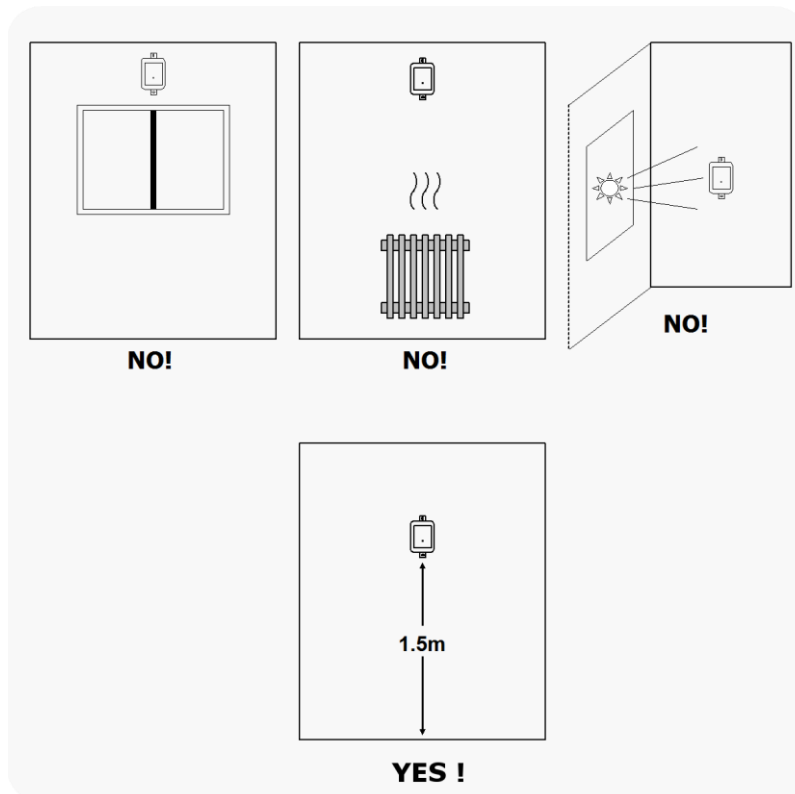

Picture 6 - Device positioning



**7. Wireless device user interface.**

The user interface consists of a “virtual” button that can be activated using the [WineCapKey](#) and of a two-coloured led.



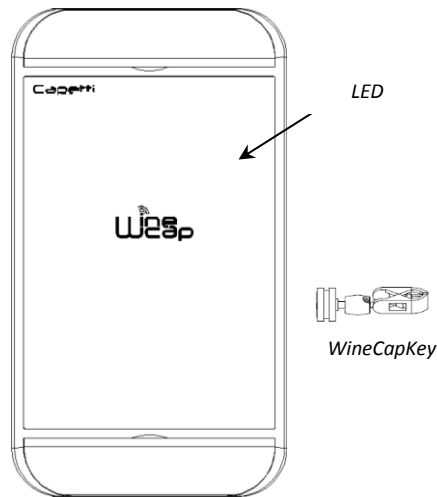



To give a command, user must approach the [WineCapKey](#) to the device’s sensible area and keep it in that position.; the following picture ([Picture 7 - WineCapKey positioning](#)) shows device’s sensible points.

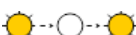

Picture 7 - WineCapKey positioning

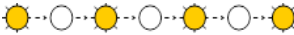
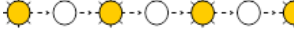

The following **COMMAND** table describes the available commands:

Flash count	Command	Description
1 flash 	<b>STATUS</b>	Shows the device STATUS. As answer the led perform a flash sequence as reported in the "STATUS" table. If the device is performing the TEST (refer to TEST command) this command stops it.
2 flashes 	<b>TEST</b>	Enter in TEST mode and transmits status and measurements every 5 seconds. If the device is in STANDBY mode or it is out of radio range, this command forces the connection procedure to the WSN and the return to the operative mode. The TEST stops after 120 seconds. During TEST the led continuously shows the STATUS to monitor the received radio signal quality. <b>CAUTION: Measures acquired during TEST phase are NOT saved.</b>
3 flashes 	<b>ENROLL</b>	Association to the network: must be used when the device has not yet been included in a network, starts the entry and association procedure to the <b>basestation</b> (refer to "WineCap System - User Manual R29").
4 flashes  + 4 flashes 	<b>STANDBY</b>	Temporary device deactivation: the device is stopped. The sampling process and the radio are/is turned off losing the connection to the network. To reactivate, a TEST command is necessary. The STANDBY command must be given twice to confirm it: at the first sequence the led flashes alternating RED and GREEN lights, waiting for the second confirm sequence within 15 seconds. At the command execution the led flashes as the STANDBY status (refer to "WIRELESS MODE STATUS Table").
5 flashes  + 5 flashes 	<b>FACTORY RESET</b>	The device performs the memory deleting procedure and goes in STOP status. All samples, configuration and wireless network data associated are LOST. To reactivate the device a new association and configuration procedure is necessary (ENROLL command). Also in this case, the FACTORY RESET command must be given twice to confirm it. At the command execution the led flashes as the "PROBE/DATALOGGER NOT ASSOCIATED" status refer to "WIRELESS MODE STATUS Table".
5 flashes  + 3 flashes 	<b>LOGGER NO WSN</b>	As the previous command but performs only the WSN deleting procedure and disassociate from the <b>basestation</b> . The device enter in LOGGER STAND ALONE mode: data are kept and the sampling activity CONTINUES with previous setup. Command must be given with 2 sequences: 5 flashes and then 3 flashes. At the command execution wait for the device reboot. At the STATUS command, "LOGGER" will be the answer (refer to "STAND-ALONE MODE STATUS Table"). A new association (ENROLL command) is possible to a new <b>basestation</b> .

Picture 8 - Commands table

## 8. Enrolling the device.

Not necessary if performed in factory before delivery.

Enroll the device to the network referring to the "[WineCap System - User Manual R29](#)". In case the device is already enrolled but in STANDBY status, a TEST command must be issued (refer to [Picture 8 - Commands table](#)).

## 9. Installation procedure.

After installing the **basestation** in appropriate place in charge, (refer to "[WineCap System - User Manual R29](#)"), be sure that the device is enrolled to the **basestation** and activated.

Head for the environment to be monitored. On the way, to check the quality of the radio coverage, use the "Field Measurer" function.

This function is activated issuing the TEST (refer to [Picture 8 - Commands table](#)) command: position the [WineCapKey](#) in the spot indicated in [Picture 7 - WineCapKey positioning](#) and wait for two AMBER flashes, then remove the [WineCapKey](#) from device. The "Field Measurer" function lasts enabled for two minutes.

To issue commands to the device, place the [WineCapKey](#) where indicated.









Once the [WineCapKey](#) is detected, the led periodically emits AMBER flashes with a 2 seconds cadence.



For each flash, a different command is associated; to confirm the command the [WineCapKey](#) must be removed from the sensible area immediately after the number of flashes corresponding at the desired command. The *TEST* corresponds to the second pulse and activate the "Field Measurer" function.

The device will give back the radio signal quality through led flashes:

**WIRELESS MODE STATUS Table**

Flash count - Wireless mode	Status/Radio signal quality
 5 green flashes	Excellent
 4 green flashes	Good
 3 green flashes	Fair
 2 amber flashes	Sufficient
 1 red flash	Insufficient
 1 red flash 2" long	OUT OF RANGE Network searching
 2 red flashes 2" long	STANDBY
 Short-long-short red flashes series	FACTORY RESET Device not enrolled

Picture 9 - Status table - Radio signal quality

Optimize reception selecting the best position: small movements can help.

If the signal is absent or insufficient at the install point, a [WR12 router](#) should be put between (refer to "[WineCap System - User Manual R29](#)"). The [WR12 router](#) itself must be located in a position where the signal level is at least sufficient.

The network will reconfigure itself automatically; the signal will be good again when the device synchronizes with the [WR12 router](#).

The link will not be reconfigured until completely lost by the device. Because of this, in some cases it could be necessary to force the operation. In such cases, put the device in *STANDBY* mode, then run the *TEST* again (refer to "[WineCap System - User Manual R29](#)").

**NOTE:** The display equipped **datalogger** ([WD04T](#)) is recommended, to verify the signal quality during devices installation.



## 10. Stand-alone USB datalogger installation.



Install the **datalogger** in appropriate place.

If the sampling process has not yet been activated you can start it through the [WineCapKey](#).

Bring it closer to the sensitive point, wait for 2 flashes (**TEST**) (refer to [Picture 8 - Commands table](#)) and remove. The **datalogger** begins sampling according to your settings through your PC.

Through the [WineCapKey](#) is possible to ask for the current status, bring it close to the **datalogger** for 1 flash (**STATE**) and remove it.

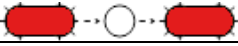
**STAND-ALONE MODE STATUS** Table:

Flash count - Stand-alone mode	STATUS
 1 green flash 2 seconds long	ACTIVE
 2 red flashes 2 seconds long	STANDBY
 Sequence of red flashes: short, 2 seconds long, short	FACTORY RESET <b>INVALID datalogger</b> clock! PC connection required

Picture 10 - Stand-alone datalogger status

## 11. Shutting off/Reactivating the device.

If the device is shut off and left unused for a long time, you can issue the **STANDBY** command (refer to [Picture 8 - Commands table](#)). Its corresponds to the command number 4 and must be issued twice to confirm the operation.

Position the [WineCapKey](#) in the spot indicated in [Picture 7 - WineCapKey positioning](#) and wait for four **AMBER** flashes, then remove the [WineCapKey](#) from device.

Verify that the device asks for confirmation of **STANDBY** command with alternate **GREEN/RED** flashing, then position again the [WineCapKey](#) and wait for four flashes again. The device will confirm the **STANDBY** status lighting the **RED** led for 2 seconds twice.

To reactivate the device the **TEST** command must be issued.

## 12. Transducer's connection layout.

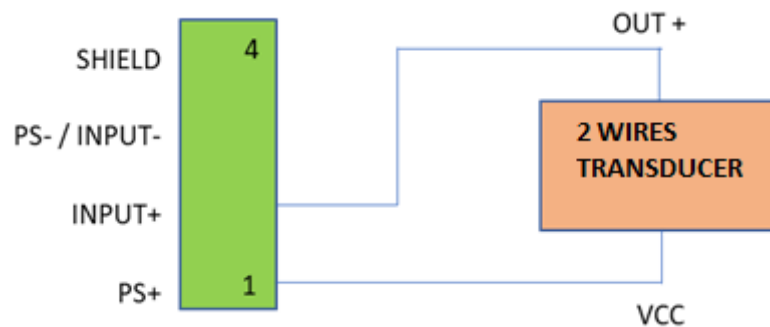

Picture 11 - 2 wires transducer connection layout



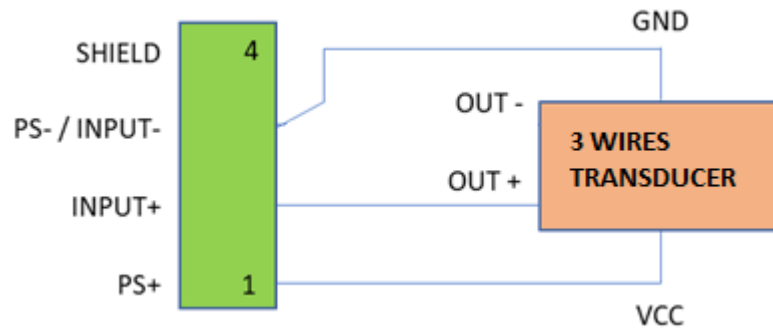

Picture 12 - 3 wires transducer connection layout

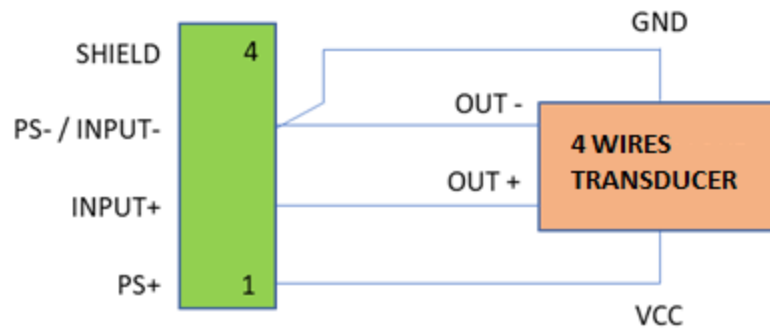

Picture 13 - 4 wires transducer connection layout



### 13. Technical Information.

Power supply	Dual 5,8A/h - 3,6 V type "C" lithium internal battery
Battery life (*)	Up to 3 years <i>(samples every 60 minutes, with 100mA of 12V power load and radio signal quality at least sufficient)</i>
Power supply generated for transducers	+12Vdc or +24Vdc (up to 100mA) - (Selectable onboard using jumpers)
Sampling interval (*)	Selectable from one minute to 24 hours (60 minutes default)
Datalogger capacity	64,000 samples
Working temperature	<ul style="list-style-type: none"> <li>Operative: -30°C ÷ +60°C</li> <li>Warehousing: -40°C ÷ +70°C</li> </ul>
Radio frequency	ISM 868MHz
Radio coverage 	Up to 6Km in line of sight <i>(can be extended using <a href="#">WR12</a> battery powered routers)</i>
Sealing	IP65
Dimensions	90 x 160 x 50mm
Weight	450g
Case material	ABS
Mounting	Fix on 4 points
Connections	Wireless/USB
Cable external diameter	3mm minimum - 6.5mm maximum
Copper wire section	0.05 ÷ 2.5mm <sup>2</sup> / ÷ 14 AWG
Measures acquired (4 channels) - Possible Input Signals (up to 4)	<ul style="list-style-type: none"> <li>0÷5V, 0÷10V</li> <li>0÷25Vdc, 0÷25mA</li> </ul>
Measures acquired (4 channels) - Resolution	12 bits converter
Measures acquired (4 channels) - Measurement Expression	Expressed as full scale % setting
Measures acquired (4 channels) - Transducers Connection	Through 5mm pitch screw terminal blocks
Measures acquired (4 channels) - Settings <i>(measure/system of measure)</i>	Using jumpers (***)

\* battery life may be influenced by fieldwork conditions, sampling interval and system configuration.

\*\* radio coverage reachable using up to 32 [WR12 routers](#) (maximum 16 for each path) between the device and the basestation.

\*\* refer to selected transducer's documentation. Setup jumpers in proper way.



14. Mechanical dimensions.

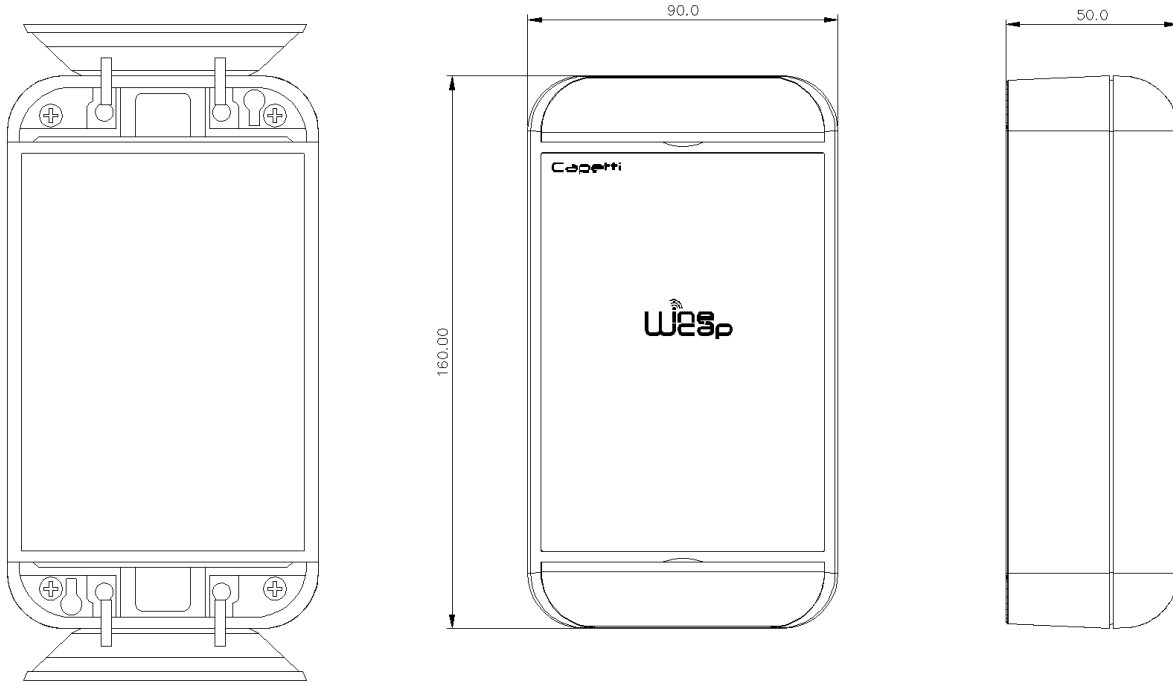

Picture 14 - Mechanical dimensions



---

**15. Reference standards.**

EN 61010 -1

For electromagnetic compatibility

EN 61000 - 3 - 2

EN 61000 - 3 - 3

EN 300 220 -2

EN 301 489 - 03

EN 61000 - 6 -1

---

This symbol indicates that this product is compliant with the European Directive 2011/65/CE that restricts the use of substances in the manufacturing of electronic devices.



---

The "WEEE" logo on the label indicates that this product is compliant with the "WEEE" EC Directive. This symbol (valid only in the European Union countries) indicates that the product it is applied to, MUST NOT be discarded with ordinary household or industrial waste, but must be sent to an authorized reception point. The end user should contact the device provider, either the manufacturer or the reseller, in order to agree a collection and disposal process, after having checked the terms and conditions of sale.



IT190200000111

---

*The features shown may be subject to change without notice.*