



# **IoT Sensor plus**

## **Instructions for use**

W0841  
W0841E  
W6810  
W8810  
W8861

Temperature, relative humidity, atmospheric pressure and  
CO<sub>2</sub> concentration transmitters for the SIGFOX network

---

© Copyright: COMET SYSTEM, s.r.o.

This manual is forbidden to copy and make changes of any nature without the express consent of COMET SYSTEM, s.r.o. All rights reserved.

COMET SYSTEM, s.r.o. constantly developing and improving its products. Therefore, it reserves the right to make technical changes to the device / product without prior notice.

Contact the manufacturer of this device:

COMET SYSTEM, s.r.o.  
Bezrucova 2901  
756 61 Roznov pod Radhostem  
Czech Republic  
[www.cometsystem.com](http://www.cometsystem.com)

---

# Content

<b>CONTENT .....</b>	<b>3</b>
<b>INTRODUCTION.....</b>	<b>4</b>
<b>SAFETY PRECAUTIONS AND PROHIBITED HANDLING.....</b>	<b>5</b>
<b>INSTALLATION .....</b>	<b>6</b>
Device Mounting .....	6
Switching the device on .....	8
Device display.....	8
Device usage and settings .....	10
Alarm functions .....	11
<b>MANUFACTURED MODELS .....</b>	<b>14</b>
<b>APPLICATION NOTES .....</b>	<b>17</b>
<b>OPERATING AND MAINTENANCE RECOMMENDATIONS.....</b>	<b>19</b>
<b>TECHNICAL PARAMETERS .....</b>	<b>21</b>
Power supply .....	21
Measurement and transmission of data .....	22
RF part of device.....	22
Electromagnetic compatibility.....	23
Operating and storage conditions .....	23
Mechanical properties.....	23
Transmitter Input Parameters.....	24
Dimensional drawings.....	28
Declaration of Conformity.....	30
<b>APPENDICES .....</b>	<b>31</b>

---

# Introduction

The Sigfox network is used to transmit very short data messages and is optimized for low power consumption. It operates in the unlicensed radio band, which brings cheaper traffic, but also legislative restrictions - messages can not be sent faster than with a 10 minute interval.

Ideal applications for transmitters working in the Sigfox network are those where it is sufficient sending measured values with longer intervals (eg 1 h or longer). Conversely, inappropriate applications are those where fast system response (less than 10 minutes) is required.

The WX8xx series transmitters for the SIGFOX network are designed to measure::

- temperature
- relative air humidity
- relative air humidity
- CO<sub>2</sub> concentration in air

The transmitter performs a measurement every 1 minute. The measured values are displayed on the LCD and are sent over an adjustable time interval (10 min to 24 hour) via radio transmission in the Sigfox network to the cloud data store. Through a common web browser, the cloud allows you to view both actual and historical measured values. Transmitter setup is done either by computer (locally, by communication cable) or remotely via the cloud web interface.

For each measured variable, it is possible to set two alarm limits. The alarm is signalled by the symbols on the LCD display and sending an extraordinary radio message to the Sigfox network, where it is forwarded to the end user by e-mail or SMS message. Extraordinary messages can also be sent by the transmitter if the binary input state is changed (if equipped). The device is powered by an internal Li battery whose lifetime is dependent on the transmission range and operating temperature and ranges from 4 months to 7 years. The battery status information is on the display and in each sent message.

The Wx8xx series transmitters are designed with increased resistance to external influences (especially water protection), see technical data. Operation without an internal battery (with external power only) is not possible.

---

## Safety Precautions and Prohibited Handling



Read the following safety precautions carefully before using the appliance, and keep it in mind during use!

- The device includes a radio transmitter operating in the non-license frequency band with the power specified in the Technical Parameters. This band and performance are used in the countries of the European Union. If you are in another location, make sure you can use the device before turning it on for the first time.
- Do not use the device in places where the use of mobile phones, such as near sensitive medical devices, is restricted on the aircraft or in places where blasting is taking place.
- Observe the authorized storage and operating conditions listed in the Technical Specifications. Take care not to subject the unit to temperatures above 60 °C. Do not expose it to direct sunlight, including solar radiation.
- It is forbidden to use the transmitter in a hazardous environment, especially in areas with the risk of explosion of flammable gases, vapours and dust.
- It is forbidden to operate the unit without a cover. After replacing the battery or changing the instrument settings using the SP003 cable, check the seal integrity and screw the device with the original screws. Always follow the instructions in this manual carefully.
- Do not expose the device to aggressive environments, chemicals or mechanical shock. Use a soft cloth to clean. Do not use solvents or other aggressive agents.
- Do not attempt to service yourself. Any repairs may only be performed by trained service personnel. If the device has unusual behaviour, unscrew the device cap and remove the battery. Contact the distributor from whom you purchased the device.
- The device uses wireless communications and SIGFOX networks. For this reason, the connection cannot always be guaranteed and under all circumstances. Never rely exclusively on wireless devices for critical communication purposes (rescue systems, security systems). Keep in mind that redundancy is required for systems with high operational reliability. More detailed information can be found e.g. in IEC 61508.
- The device contains a special type of battery with other parameters than conventional AA batteries. Use the type recommended by the manufacturer in the Technical Parameters (Tadiran SL-2770/S, 3.6 V, C size).
- Replace the battery only with a person who knows the principles of safe handling of lithium primary batteries. Apply the used batteries to hazardous waste. In any case, do not throw them into a fire, expose them to high temperatures, low air pressure and do not mechanically damage them.
- Only use the manufacturer's recommended accessories.

---

# Installation



Installation, commissioning and maintenance must only be carried out by a qualified person in accordance with applicable regulations and standards.

## Device Mounting

For the optimum operation of the Wx8xx Series, it is necessary to ensure their vertical position, usually by screwing them on a wall or other suitable vertical surface at the place of installation of the device. The sensor boxes are provided with 4.3 mm diameter holes for fastening with suitable screws. The holes are accessible after removing the cover. Fix the device firmly only after verifying the reception of the radio signal at the required installation location (see chapter *Switching the device on*).

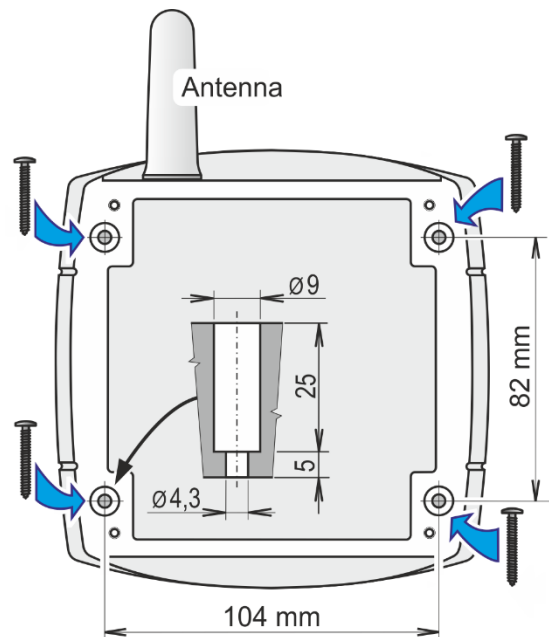

### Basic placement rules:

- always install the transmitters vertically, with the antenna cover up, at least 10 cm away from all conductive objects
- do not install the devices in underground areas (the radio signal is generally unavailable here). In these cases, it is preferable to use the model with an external probe on the cable and place the device itself, for example, one floor above.
- the devices and all cables (probes, binary inputs) should be placed away from electromagnetic interference sources
- temperature and relative humidity transmitters, or their probes should be placed so that the measured values are not affected by accidental heat sources (sunshine ...) and unwanted airflow

---

### Optimal positioning of the transmitter in terms of radio range:

All materials absorb radio waves if they must pass through them. The most significant in terms of radio wave propagation are metal objects, concrete, reinforced concrete and walls. If you install the device at a greater distance from the base station or in locations where the radio signal difficult to penetrates, observe the following recommendations:

- place the device as high as possible with the antenna better in open space than near the wall
- in rooms place the device at least 150 cm above the floor and if possible not directly on the wall. For safety reasons, you do not exceed the installation height of 2 m above the floor (the fall of the insufficiently attached device can be dangerous).
- place the device at a sufficient distance (at least 20 cm) away from all obstacles that could cause attenuation of the radio waves and at least 20 cm from the neighbouring device in the case that you use multiple devices
- lead the cables of the external measuring probes and the external power first down to the distance of at least 40 cm from the instrument. If the cable is too long, install it by the figure.
- do not use probes with a cable shorter than 1 m

Examples of optimal and less suitable positioning of the device:

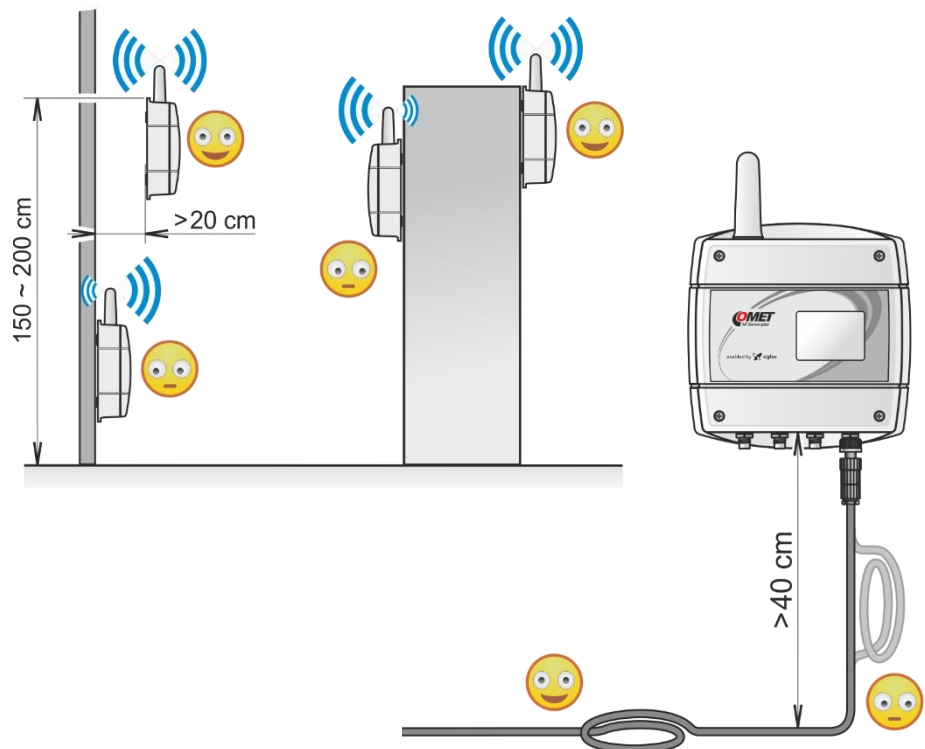

---

## Switching the device on

The device is supplied with installed battery, but in off state. The CONFIGURATION button is used to turn on the device:

- models without waterproof cover (W0841E, W6810, W8810) have a CONFIGURATION button accessible via a paper clip through the hole on the top of the device
- waterproof models (W0841 and W8861) have a CONFIGURATION button under the cover. Unscrew the four screws at the corners of the box and remove the cover.
- press the CONFIGURATION button (see figures on the right) and release it as soon as the LCD lights up (through the 1 s)
- perform the installation and if necessary set up the device too (see chapter *Device usage and settings*)

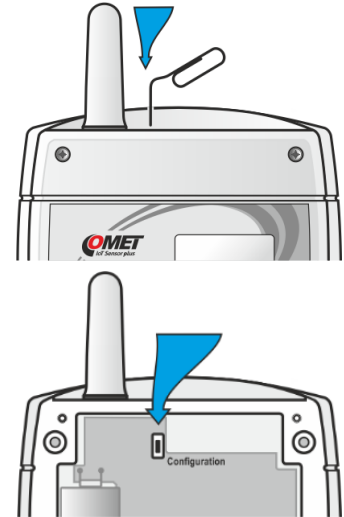

- finally, carefully screw on the cover. For waterproof models, making sure that the gasket in the housing groove is correctly positioned.

## Device display

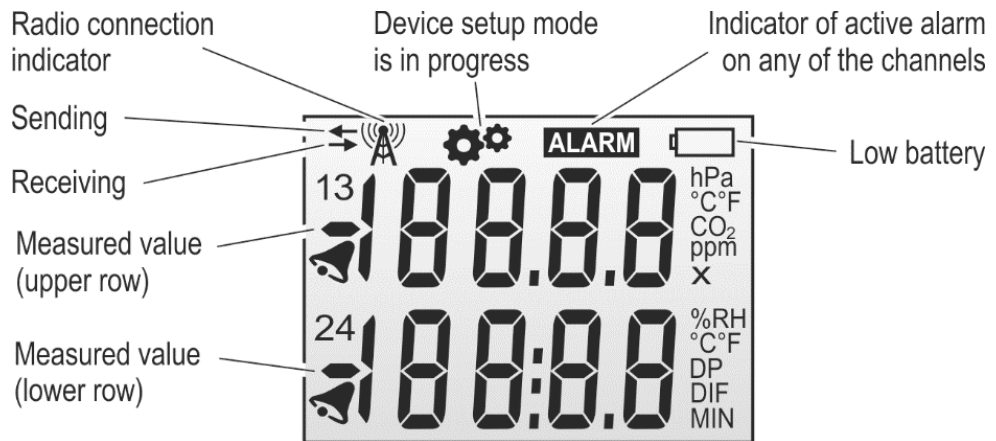

**Radio Connection Indicator** – Indicates the result of checking the bi-directional radio connection with the cloud, which takes place once a day. This connection allows the transmitter to be set remotely. If the radio connection check is successful, the indicator will remain lit until the next scan. When the transmitter is switched on, the indicator lights up after 24 h (a good radio signal is required). The Radio connection indicator may light up sooner if the user deliberately selects the transmitter setting mode by pressing the CONFIGURATION button and it is correctly performed.



---

If the remote setting in the device is disabled, the bi-directional connection check to the cloud is not performed and the radio connection indicator remains off.

**Low Battery Symbol** – Illuminates if the battery is already weak and flashes when the battery is in critical condition (see the *How to replace the battery* chapter for details)

**Information on the display** – they are displayed cyclically in three steps (the images below contain only examples of the display, the content of the display always depends on the specific model):

**1. step** (lasts 4 sec) the display shows data on measured quantities on channels No.1 and No.2

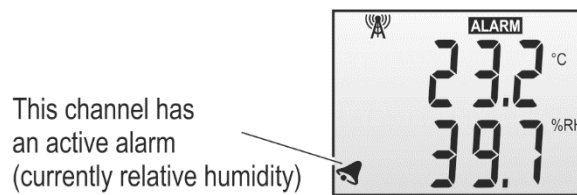

**2. step** (lasts 4 sec) the display shows data on measured quantities on channels No.3 and No.4

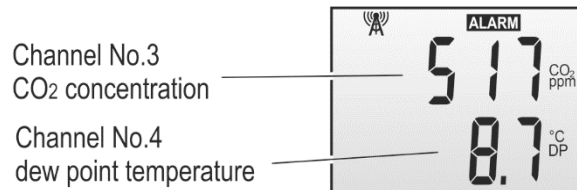

**3. step** (lasts 2 sec.) The display shows the service information about the time of sending regular messages and external power supply

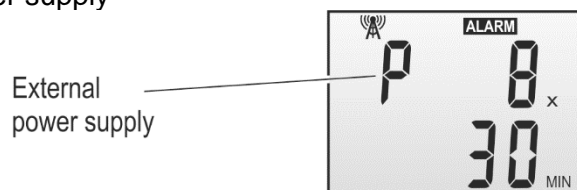

**P (Power)** – information about presence of external power supply is refreshed with interval of 1 min.

**8x** – shows how many times the regular message will be sent before the new transmitter setup (if this requirement is currently set in the cloud). The information is reduced with each regular report sent. Reading the new settings from the cloud occurs when the display shows "1x 0 min". If the remote setting is in the device disabled, this value is not displayed.

**30 min** – the time in minutes until a regular message with measured values is sent (the information decreases every minute from the currently set sending interval to 0).

---

## Device usage and settings

### Factory setting

- message sending interval of 10 minutes
- alarms deactivated
- remote setting enabled
- for devices with pressure measurement set altitude 0 m (the device displays absolute atmospheric pressure)

## Working with the cloud

---

### Viewing measured values

Cloud is an internet storage of data. You need a PC with internet connection and a web browser to work with. Navigate to the cloud address you use and sign in to your account - if you use COMET Cloud by a transmitter manufacturer, enter [www.cometsystem.cloud](http://www.cometsystem.cloud) and follow the instructions in the *COMET Cloud registration* document that you received with your device.

Each transmitter is identified by its unique address (device ID) in the Sigfox network. The transmitter has an ID printed on the nameplate along with its serial number. In the list of your device in the cloud, select the device with the desired ID and start viewing the measured values.

### Checking the signal quality during device installation

The device in factory default setting will send the measured values every 10 minutes. Check in the cloud for messages to be received. Place the device temporarily to the location where it will perform the measurements and check the quality of the radio signal - in COMET Cloud click on the correct device in the *My Devices* list and then select *Installation*. If you have a problem with the signal, see the *Problems with receiving radio messages* chapter.

### Change of device settings remotely

The transmitter can be set remotely from the cloud if the cloud you use supports this feature. Run the remote setting feature - in COMET Cloud click on the correct device in the *My Devices* list and then select *Configure*. Set the desired sending interval (taking into account the fact that for short sending intervals the battery life decreases), the limits, delays and hysteresis of the alarms for the individual quantities (if used), or correction of the altitude atmospheric pressure (only models with air pressure measurement). Save the new setting. The device will accept this new setting within 24 hours at the latest.

If you are running a new transmitter and want to speed up the setting, press the CONFIGURATION button (the device must be switched on beforehand) - the setting symbol  (gears) lights up and the device will start transmitting the new setting from the cloud within 10 minutes. The

---

transmission itself will take up to 40 minutes depending on the range of the new settings. The function can only be used once every 24 hours. The location of the CONFIGURATION button varies depending on the transmitter model. For details, see *Switching the device on* chapter.

## Working with the COMET Vision SW

### Change of device settings by connecting to a PC

The transmitter can be set directly from the PC using the SW COMET Vision and Communication Cable SP003 (Optional accessory). Software COMET Vision is downloadable on the web [www.cometsystem.com](http://www.cometsystem.com), as well as a manual for its installation and use.

Unscrew the device cover and connect it to the SP003 cable with the USB port on the computer. Start the Comet Vision program and make a new device setting. After you have saved the new settings, unplug the cable and screw the device cover carefully. For waterproof devices, pay attention to the correct seal position.

**Warning** - do not leave the communication cable SP003 connected to the transmitter if the cable is not connected to the PC USB port at the same time or if the PC is switched off! The battery consumption in these cases increases and the battery is drained unnecessarily.

## Alarm functions

The transmitter sends the measured values in regular messages, according to the set sending interval. In addition, the transmitter can also send extraordinary alarm messages when a new alarm is generated on a tracked channel or the alarm in progress is extinguished. This feature allows you to extend the battery life by setting a longer sending interval for regular messages, and the user is informed about changes in the alarm status by extraordinary messages according to the current situation.

### Overview of transmitter properties for correct alarm function settings

- two alarms can be set for each channel (or measured quantity)
- each alarm has an adjustable limit, direction of exceeding the limit, delay and hysteresis
- alarm delay can be set to 0-1-5-30 min except CO<sub>2</sub> channel, which has adjustable delay only to 0 or 30 min
- the longer the sending interval for regular messages, the greater the battery capacity is saved.

- after a new alarm is triggered (or an alarm is ended), an extraordinary alarm message is sent within 10 minutes at the latest. Temporary interruption of the current alarm (max. 10 min) is not indicated. See the examples in pics below.
- the content of both regular and extraordinary alarm messages is identical, both contain the measured values of all channels and current alarm states on all channels
- no even a short-term alarm (i.e. with a duration of 1 to 10 min) will not be lost – the information will be sent no later than 10 min even if the alarm is currently inactive. Device in alarm message sends the maximum value measured during the alarm duration (or the minimum value, depending on the current alarm threshold setting). See the examples in pics below.
- due to the regulation of the unlicensed radio band, the device can not send messages faster than every 10 minutes. If the device has fastest sending interval (ie 10 minutes), no extraordinary alarm messages can be sent

### Examples of sent alarm messages triggered by changes in the measured value (eg temperature)

Device configuration:

- sending interval: 30 min
- alarm for channel temperature: ON
- alarm will be activated if: value is greater than limit
- limit of alarm: any value
- delay of alarm: none
- hysteresis: 0 °C

After a new alarm is triggered, an extraordinary alarm message is sent within 10 minutes at the latest. Temporary interruption of the current alarm (max. 10 min) is not indicated. After ended of alarm, an extraordinary alarm message is sent within 10 minutes at the latest.

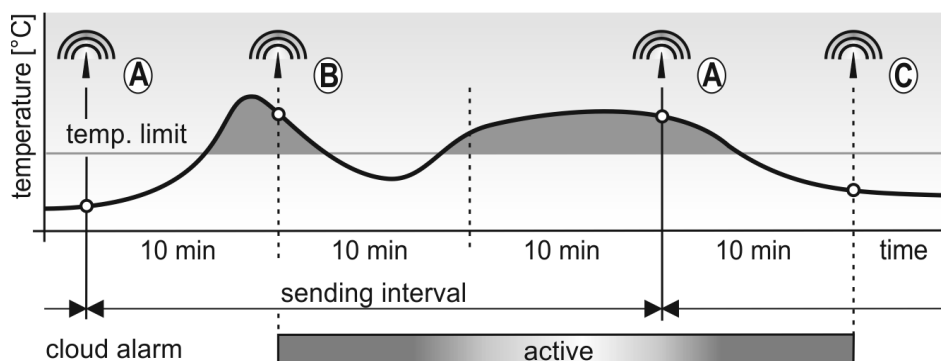

- (A) regular message sent in sending interval
- (B) extraordinary message - start of alarm
- (C) extraordinary message - end alarm

---

No even a short-term alarm (i.e. with a duration of 1 to 10 min) will not be lost – the information will be sent no later than 10 min even if the alarm is currently inactive. Device in alarm message sends the maximum value measured during the alarm duration.

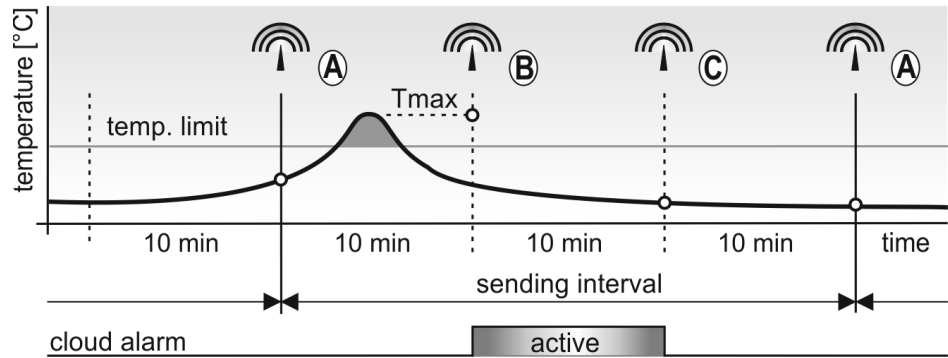

- (A) regular message sent in sending interval
- (B) extraordinary message - start of alarm
- (C) extraordinary message - end alarm

---

## Manufactured models

COMET's Wx8xx transmitters differ in the type of measured quantities (temperature, relative humidity, atmospheric pressure, CO<sub>2</sub> concentration) and the location of the sensors (compact design with internal sensors or external probes on the cable).

The enclosure covers electronic circuits, internal sensors, and a one or two batteries. Depending on the type, the devices are fitted with connectors. The antenna is protected by a cap.

Features overview of individual models:

	<b>W0841</b>	<b>W0841E</b>	<b>W6810</b>	<b>W8810</b>	<b>W8861</b>
possibility of external power supply	NO	YES	YES	YES	NO
slot for 2nd battery	NO	NO	NO	YES	YES
protection against dust and water	YES	NO	NO	NO	YES

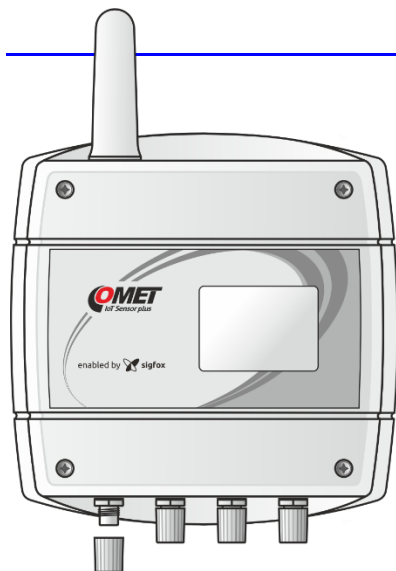

---

### W0841

#### Four inputs transmitter for external Pt1000 probes with Elka connector

The transmitter measures the temperature from four external probes of the Pt1000/E line (the probe is not part of the instrument). Response to the jump temperature change is usually much faster than the models from the internal sensor. The transmitter is often used to monitor locations where only a measuring probe is installed and the device itself is in a suitable location from a radio range point of view. The maximum recommended probe length is 15 m. The transmitter has increased protection against external influences (dust, water, humidity). Supplied with connector caps for unused temperature inputs.

---

## W0841E

---

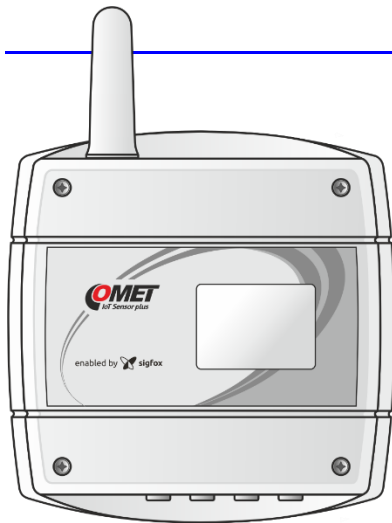

### Four inputs transmitter for external Pt1000 probes with Cinch connector

The transmitter measures the temperature from four external probes of the Pt1000/E line (the probe is not part of the instrument). Response to the jump temperature change is usually much faster than the models from the internal sensor. The transmitter is often used to monitor locations where only a measuring probe is installed and the device itself is in a suitable location from a radio range point of view. The maximum recommended probe length is 15 m. The transmitter is equipped with an external power input.

---

## W6810

---

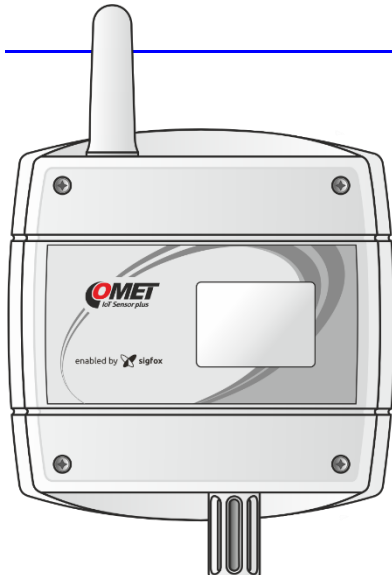

### Compact temperature, relative humidity and CO<sub>2</sub> concentration transmitter

The transmitter measures the temperature, relative humidity and dew point temperature by means of internal sensors located under the cap with a stainless-steel air filter. The CO<sub>2</sub> concentration is measured by a sensor located inside the transmitter box, which is equipped with vents at the top. The device is characterized by a simple compact design, but a relatively longer response to a step change of measured quantities than those with an external probe. The instrument is placed directly into the measured area. The transmitter is equipped with an external power input.

---

## W8810

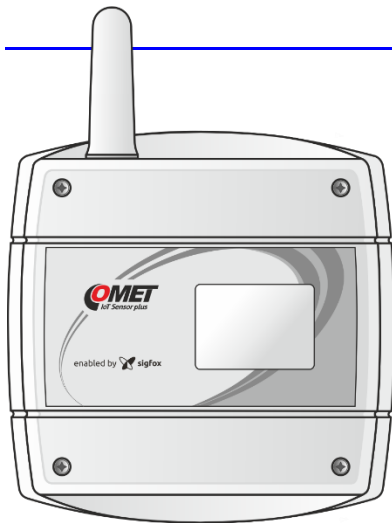

### Compact temperature and CO<sub>2</sub> concentration transmitter

The transmitter measures the temperature and the CO<sub>2</sub> concentration by a sensors located inside the transmitter box, which is equipped with vents at the top. The device is characterized by a simple compact design, but a relatively longer response to a step change of measured quantities than those with an external probe. The instrument is placed directly into the measured area. The transmitter is equipped with an external power input and an slot for 2nd battery, allowing for extended battery operation.

---

## W8861

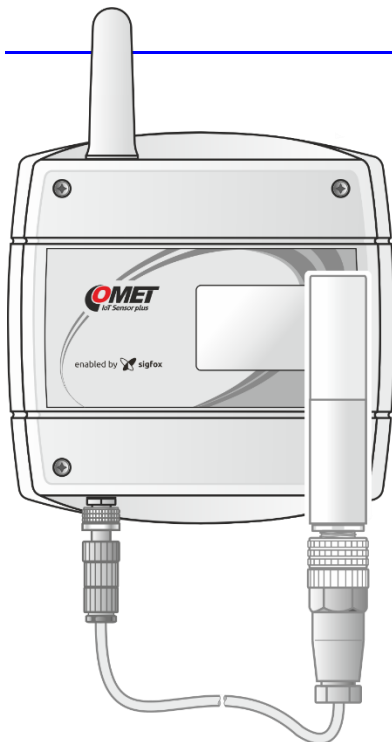

### Transmitter with input for external probe measuring CO<sub>2</sub> concentration, with internal temperature and atmospheric pressure sensors

The transmitter measures temperature and atmospheric pressure from built-in internal sensors and CO<sub>2</sub> concentration from an external probe of the CO<sub>2</sub>Rx/E series (not included). The transmitter allows to measure higher CO<sub>2</sub> concentrations (depending on the used probe) and with faster response compared to devices with internal CO<sub>2</sub> sensor. Conversely, the response of the sensor to a step change in temperature is relatively slow. The CO<sub>2</sub>Rx/E probes provide calibrated readings and are therefore interchangeable without interfering with instrument settings. The maximum recommended probe length is 4 m. The transmitter has increased protection against external influences (dust, water, humidity) and is equipped with an slot for 2nd battery, allowing for extended battery operation.



---

# Application notes

## Operation of transmitter in various applications \_\_\_\_\_

Prior to commissioning, it is first necessary to assess whether its use is appropriate for the purpose, to determine its optimum setting and, if it is part of a larger measuring system, to prepare a metrological and functional control.

Inappropriate and risky applications: The transmitter is not intended for applications where the failure of its operation could directly endanger the lives and health of persons and animals or the function of other devices that support life functions. For applications where failure or malfunction could result in serious property damage, it is recommended that the system be supplemented by a suitable independent signalling device that evaluates this status and, in the event of a malfunction, prevents the damage (see chapter *Safety precautions and forbidden handling*).

Device location: Follow the guidelines and procedures in this manual. If possible, select the location for the device where it is minimally affected by external environmental influences. If you perform measurements in fridges, metal boxes, chambers, etc., place the device outside the exposed area and insert external probe(-s) only.

Location of temperature sensors: Place them in places where there is sufficient airflow and where you anticipate the most critical location (according to application requirements). The probe must be sufficiently inserted or otherwise sufficiently connected to the measured area to prevent any influence of the measured values by the undesirable heat supply on the wires. If you monitor the temperature in the air-conditioned store, do not place the sensor in the air conditioner direct flow. E.g. in large chamber refrigerators, the distribution of the temperature field can be very inhomogeneous, deviations may reach up to 10 ° C. You will also find the same deviations in the deep-freeze box (e.g. for blood freezing, etc.).

The location of the humidity sensors depends again on the application requirements. It is very problematic to measure moisture in refrigerators without moisture stabilization. Switching on / off cooling may cause significant changes in humidity to a range of tens of percent, even if the humidity mean value is correct. Humidity condensation on the walls of the chambers is common.

## Measurement of calculated humidity variables \_\_\_\_\_

The instrument from the calculated humidity variables only provides the dew point temperature. Further calculated humidity quantities can be obtained at the level of further data processing in SW.

---

## Measurement of atmospheric pressure \_\_\_\_\_

Models with atmospheric pressure measurement allow display on sea level pressure readings. In order for the conversion to be correct, you must, during device configure, enter the altitude at which the device will be located. Altitude can be entered either directly, in the form of altitude data, or indirectly, as an offset of absolute pressure. Offset of pressure is the subtraction of pressure required (ie converted to sea level) minus absolute pressure.

When converting pressure to sea level, the device takes into account the temperature of the air column at the point of air pressure measurement.

**Therefore, it is necessary to place the device with the altitude correction in the outdoor.** If this device is placed in a heated room, the error in the recalculated pressure measurement will increase with the temperature difference between the device and the outdoor air increases.

## Problems with measurement accuracy \_\_\_\_\_

Incorrect measured values of temperature and relative humidity are most often caused by inadequate probe position or measurement methodology. Some notes on this issue are listed in the chapter *Operation of transmitter in various applications*.

Another group of problems are random peaks in the measured values. Their most common cause is the source of electromagnetic interference near the instrument or cables. In addition, it is also necessary to focus on whether cable insulation is damaged in any place and that there are no accidental connections of conductors with other metal parts.

## Problems with receiving radio messages \_\_\_\_\_

The causes of the problems can be many. If the receive of radio messages does not work at all, you can try the following steps:

- check whether the display is on and that the battery is weak
- verify that the set transmission interval matches your expectations (on the bottom line of the display, with of the 10 seconds interval always for 2 seconds shows the number of minutes left until the message is sent)
- verify the coverage of the SIGFOX network for the transmitter (<https://www.sigfox.com/en/coverage> or more detailed <http://coverage.simplecell.eu/>)
- transmitting from the interior of some buildings can be difficult, from basements, as a rule, impossible. For testing purposes, therefore, position the device as high as possible above the floor, put it on the window, or even on the outside window sill (secure the device against falling). If possible, test the location of the transmitter in other parts of the building with respect to the world's sides.

---

# Operating and maintenance recommendations

## Recommendations for metrological control \_\_\_\_\_

Metrological verification is performed according to the requirements of your own application in user-defined terms. In some cases, the calibration must be performed by an independent state-accredited laboratory.

## Recommendations for regular checks \_\_\_\_\_

The manufacturer recommends that the system in which the device is incorporated be checked at regular intervals. The range and scope of the tour depends on the application and the user's internal regulations. It is recommended to perform these checks:

- metrological verification
- regular checks at intervals as specified by the user
- evaluation of all the problems that have occurred since the last inspection
- visual inspection of the device, check the condition of connectors and cables, and cover integrity

## How to replace the battery \_\_\_\_\_



The battery may only be replaced by a person who knows the principles of safe handling of lithium primary batteries. Do not throw them into a fire, do not expose them to high temperatures, and do not mechanically damage them. Dispose the used batteries to hazardous waste.

If the low battery symbol  starts to appear in the COMET cloud received messages during operation, it is advisable to replace the transmitter battery in the next 2-3 weeks. The empty battery symbol also appears on the device display. A low battery indication may also occur if the device is operated at extremely low temperatures even when the battery is still usable (usually outdoors when in out-of-night messages). During the day (after temperature rise), the indication disappears. In this case, it is not necessary to change the battery.

A critically weak battery that can fail at any time is indicated by a blank battery symbol  in the COMET cloud and flashing the empty battery symbol on the device display. Replace the battery as soon as possible.

Note: When operating the transmitter at very low temperatures, the flashing of the blank battery symbol may not be on the sensor display visible.

---

To replace the battery, unscrew the device cover, remove the old battery and insert the new battery with the **correct polarity**. Refer to the battery symbol + (plus pole) printed on the electronics board at the battery location:

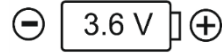

For models with two battery slots: 1 or 2 batteries can be fitted. If you decide to use two batteries, always use pieces of the same type and manufacturer, from one supply, ie. of the same age. Always use new, unused batteries. **It is forbidden to mix batteries of different manufacturers or to mix new batteries with used ones.** If you use only one battery, you can fit it into any slot.

Check the seal integrity in the housing (if equipped) and reinstall the cover. Batteries can be purchased under their designation (SL2770/S) or, if purchased from the manufacturer (COMET SYSTEM, s.r.o.), under order code A4206.

## Service Recommendations

---

Technical support and service are provided by the distributor of this device. Contact is provided in the warranty sheet supplied with the device.

**WARNING** - Improper handling or use of the device results in a loss of warranty!

## End of operation

---

Disconnect the measuring probes from the device. Return the device to the manufacturer or dispose it as an electronic waste.

---

# Technical parameters

## Power supply

The device is powered by one or two an internal lithium battery, accessible after unscrewing the cover (see the section *How to replace the battery*). Some models can also be powered from an external power source. The internal battery then serves as a backup source in case of external power failure. Operation without an internal battery (external power only) is not possible.

### Power batteries

---

**Battery type:**

Lithium battery 3.6 V, C size, 8.5 Ah

*Recommended type: Tadiran SL-2770/S, 3.6 V, 8.5 Ah*

**Battery life:**

Sending interval	models with CO <sub>2</sub> measurement (W6810, W8810, W8861)		models 4x temperature (W0841, W0841E)
	1battery	2 batteries*	1battery
10 min	10 months	1 year + 8 months	1 year
20 min	1 year	2 years	2 years
30 min	1,5 year	3 years	3 years
1 h	2 years	4 years	5 years
3 h	3 years	6 years	10 years
6 h	3 years + 2 M	6 years + 4 M	> 10 years
12 h	3 years + 4 M	6 years + 8 M	> 10 years
24 h	3,5 years	7 years	> 10 years

\*) for models W8810 a W8861 only

- *the values given is valid for the operation of the device in the temperature range -5 to + 35 ° C. Frequent operation outside this range reduces battery life by up to 25%.*
- *these values apply in the case where extraordinary alarm messages are not used or only exceptionally*

### External power input

---

**Supply voltage:**

5 to 14 V DC standardly

*minimum supply voltage: 4.8 V*

*maximum supply voltage: 14.5 V*

---

**Maximum supply current:**

for model W0841E: 100 mA  
for models W6810 a W8810: 300 mA

**Power connector:**

coaxial, 2.1 x 5.5 mm 

## Measurement and transmission of data

**Measuring interval:**

1 minute (T, RH, atmospheric pressure)  
10 minutes (CO<sub>2</sub> concentration)

**Sending interval:**

adjustable for 10 minutes, 20 minutes, 30 minutes,  
1 hour, 3 hours, 6 hours, 12 hours, 24 hours

## RF part of device

**Working frequency:**

Transmission is in the band 868,130 MHz  
Reception is in the band 869,525 MHz

**Maximum transmission power:**

25 mW (14 dBm)

**Antenna:**

Internal, gain 2 dBi

**Minimum receiver sensitivity:**

-127 dBm @600bps, GFSK

**Sigfox radiation class:**

0U

**Radio configuration zone:**

RC1

**Typical range from base station:**

50 km in open field, 3 km in urban area

-----  
For correct operation, the device position must be maintained,  
the antenna vertically upward!

---

## Electromagnetic compatibility

ETSI EN 301 489-1 V1.9.2  
ETSI EN 301 489-3 V1.6.1.  
EN 61326-1 ed.2:2013

## Operating and storage conditions

### Operating temperature:

**W0841E, W6810, W8810, W8861** (-20 to +60) °C

**W0841** (-30 to +60) °C

Display visibility is within range (-20 až +60) °C

### Operating humidity:

(0 až 95) %RH

### Operating environment:

chemically non-aggressive

### Working position:

vertically, the antenna top

### Storage temperature:

(-20 až +45) °C

### Storage humidity:

(5 až 90) %RH

## Mechanical properties

### Dimensions (H x W x D):

179 x 134 x 45 mm without the cables and connectors  
attached (see dimensional drawings in detail below)

### Weight including 1pc battery:

**W0841, W0841E, W6810** 350 g

**W8810, W8861** 340 g

### Case material:

ABS/ASA

### Protection:

**W0841:** IP65 (unused inputs must be sealed with the cap provided)

**W0841E, W6810, W8810:** IP20

**W8861:** IP54, external probe CO2Rx IP65

---

## Transmitter Input Parameters

### W0841

---

**Measured variable:**

4 x temperature from the COMET Pt1000/E external probe

**Range:**

(-200 to +260) °C, sensor Pt1000/3850 ppm

**Input accuracy (without probes):**

±0.2 °C in range -200 až +100 °C

±0.2 % of measured value in range +100 až +260 °C

*Accuracy of the instrument with attached probe is defined by the above input accuracy and the accuracy of the probe used.*

**Connection method:**

Two-wire connection with compensation of errors caused by resistance wire cable. The probe is terminated by a 3-pin M8 ELKA 3008V connector. The connection method is shown in Appendix 1. Recommended length of probes Pt1000/E is up to 15 m, do not exceed a length of 30 m.

**Response time:**

Is determined by the response time of the used probe.

**Resolution:**

0.1 °C

**Recommended calibration interval:**

2 years

### W0841E

---

**Measured variable:**

4 x temperature from the COMET Pt1000/C external probe

**Range:**

(-200 to +260) °C, sensor Pt1000/3850 ppm

**Input accuracy (without probes):**

±0.2 °C in range -200 až +100 °C

±0.2 % of measured value in range +100 až +260 °C

*Accuracy of the instrument with attached probe is defined by the above input accuracy and the accuracy of the probe used.*



---

**Connection method:**

Two-wire connection with compensation of errors caused by resistance wire cable. The probe is terminated by a CINCH connector. The connection method is shown in Appendix 2. Recommended length of probes Pt1000/C is up to 15 m, do not exceed a length of 30 m.

**Response time:**

Is determined by the response time of the used probe.

**Resolution:**

0.1 °C

**Recommended calibration interval:**

2 years

---

**W6810****Measured variables:**

Temperature and relative humidity from the build-in sensor. Dew point temperature calculated from measured temperature and relative humidity.

**Range:**

Temperature: (-20 až +60) °C  
Relative humidity: (0 až 95) % RH without permanent condensation  
Dew point temperature: -60 to +60 °C  
CO<sub>2</sub> concentration in air: 0 to 5000 ppm

**Accuracy:**

Temperature: ± 0.4 °C  
Relative humidity:

- sensor accuracy ± 1.8 %RH (at 23 °C in range 0 to 90 %RH)
- hysteresis < ±1 %RH
- non-linearity < ±1 %RH
- temperature error: 0.05 %RH/°C (0 °C to +60 °C)

Dew point temperature: ± 1.5 °C at ambient temperature T < 25 °C a RH > 30 %, details see graphs in Appendix 3  
CO<sub>2</sub> concentration in air:  
50 + 0.03 × MV ppm CO<sub>2</sub> at 23 °C and 1013 hPa  
Temperature error in range -20...45 °C:  
typ. ± (1 + MV / 1000) ppm CO<sub>2</sub>/°C  
MV... *measured value*

---

**Response time (air flow approx. 1 m/s):**

Temperature:  $t_{90} < 8$  min (T change 20 °C)

Relative humidity:  $t_{90} < 1$  min (humidity change 30 %RH, constant temperature)

CO<sub>2</sub> concentration:  $t_{90} < 50$  min (change 2500 ppm, constant temperature, without air flow)

**Resolution:**

Temperature including dew point temperature: 0.1 °C

Relative humidity: 0.1 %

CO<sub>2</sub> concentration: 1 ppm

**Recommended calibration interval:**

1 year

---

**W8810****Measured variables:**

Ambient temperature and CO<sub>2</sub> concentration in air, both from the built-in sensor.

**Range:**

Temperature: (-20 až +60) °C

CO<sub>2</sub> concentration in air: 0 až 5000 ppm

**Accuracy:**

Temperature:  $\pm 0.4$  °C

CO<sub>2</sub> concentration in air:

$50 + 0.03 \times MV$  ppm CO<sub>2</sub> at 23 °C and 1013 hPa

Temperature error in range -20...45 °C:

typ.  $\pm (1 + MV / 1000)$  ppm CO<sub>2</sub>/°C

*MV... measured value*

**Response time (air flow approx. 1 m/s):**

Temperature:  $t_{90} < 20$  min (T change 20 °C)

CO<sub>2</sub> concentration:  $t_{90} < 50$  min (change 2500 ppm, constant temperature, without air flow)

**Resolution:**

Temperature: 0.1 °C

CO<sub>2</sub> concentration: 1 ppm

**Recommended calibration interval:**

2 years

---

## W8861

---

### Measured variables:

Ambient temperature and atmospheric pressure from the built-in sensor. CO<sub>2</sub> concentration in air measured by the external probe.

### Range:

Temperature: (-20 to +60) °C  
Atmospheric pressure: 700 to 1100 hPa  
CO<sub>2</sub> concentration in air: 0 to 1 % (CO2R1-x probe)  
0 to 5 % (CO2R5-x probe)

### Accuracy:

Temperature: ± 0.4 °C  
Atmospheric pressure: ± 1.3 hPa at 23 °C  
CO<sub>2</sub> concentration in air:

#### CO2R1-x probe:

Accuracy:  
±(0.01+0.05xMV) % CO<sub>2</sub> at 23 °C and 1013 hPa  
Temperature error in range -20...45 °C:  
typ. ± (0.0001 + 0.001xMV) % CO<sub>2</sub>/°C  
*MV... measured value*

#### CO2R5-x probe:

Accuracy:  
±(0.075+0.02xMV) % CO<sub>2</sub> at 23 °C and 1013 hPa  
Temperature error in range -20...45 °C:  
typ. -0,003xMV % CO<sub>2</sub>/°C  
*MV... measured value*

### Response time (air flow approx. 1 m/s):

Temperature: t<sub>90</sub> < 20 min (T change 20 °C)  
CO<sub>2</sub> concentration: t<sub>90</sub> < 10 min (change 2500 ppm,  
constant temperature, without air  
flow)

### Resolution:

Temperature: 0.1 °C  
Atmospheric pressure: 0.1 hPa  
CO<sub>2</sub> concentration in air:  
0.001 % CO<sub>2</sub> payload protocol (cloud)  
0.01 % CO<sub>2</sub> device display

### Recommended calibration interval:

2 years

---

## Dimensional drawings

**W0841**

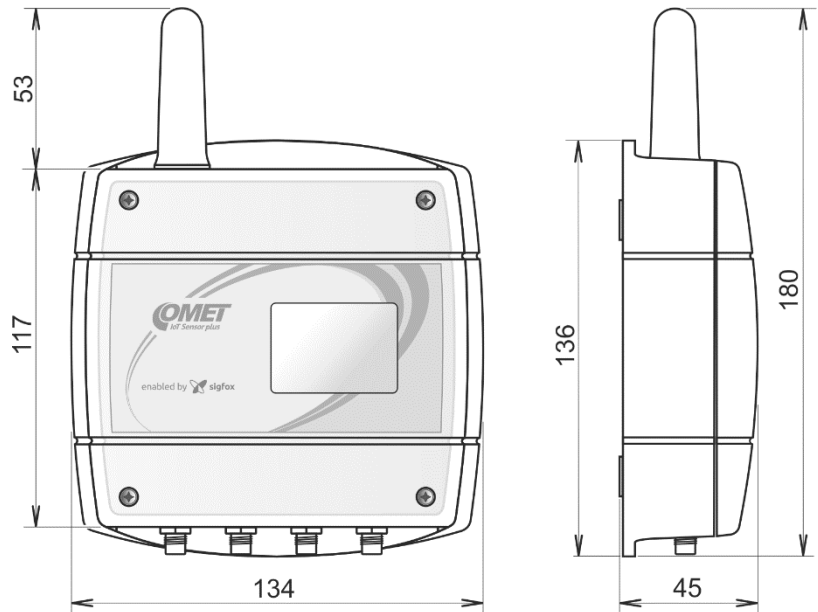

**W0841E**

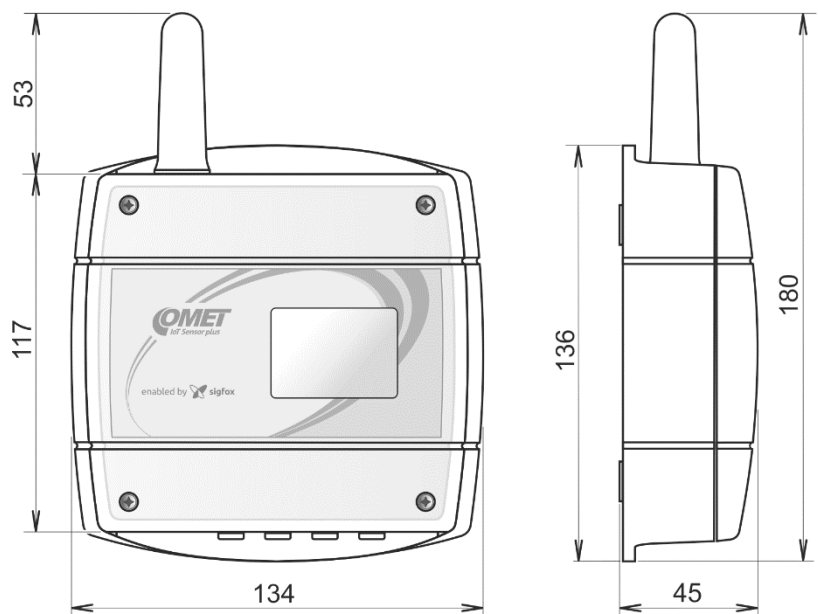

---

**W6810**

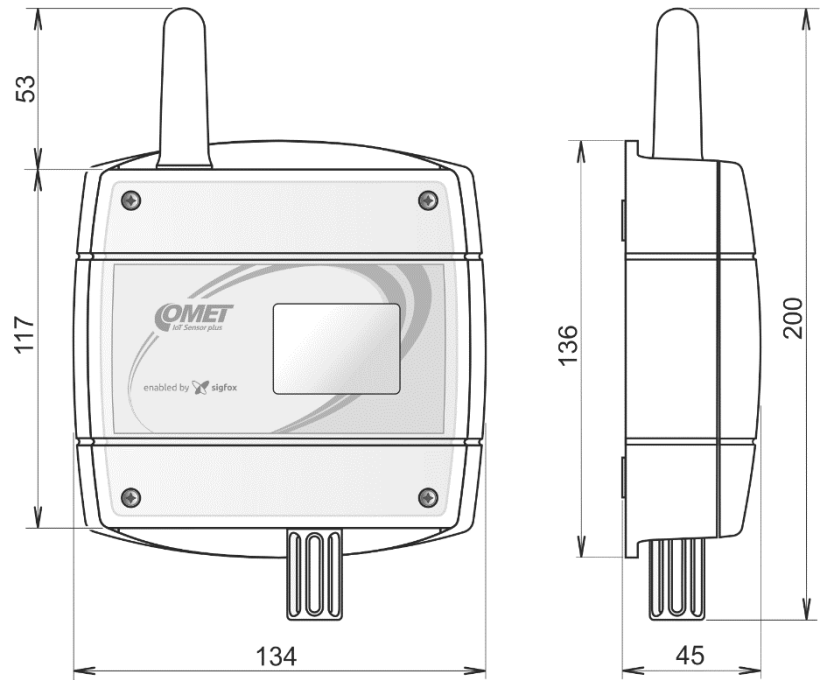

**W8810**

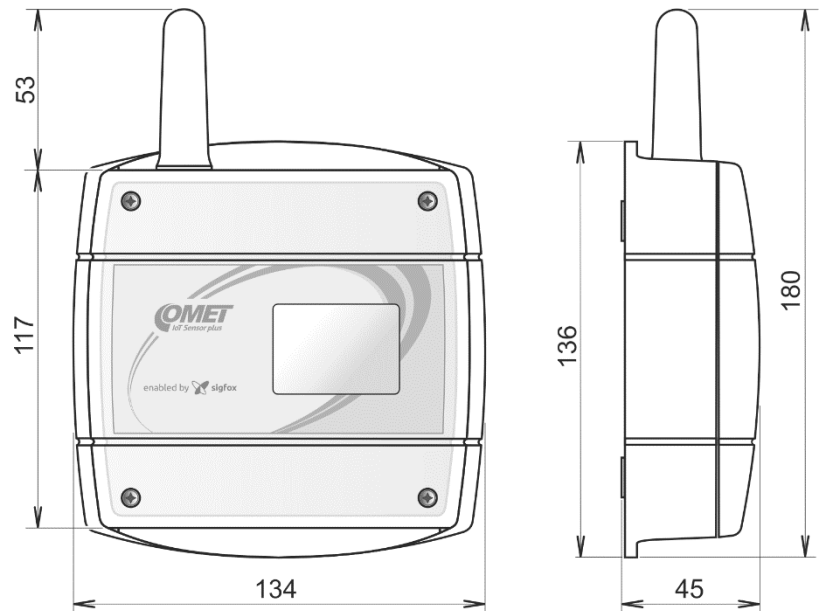

---

## W8861 and CO2R1-x (CO2R5-x) probe

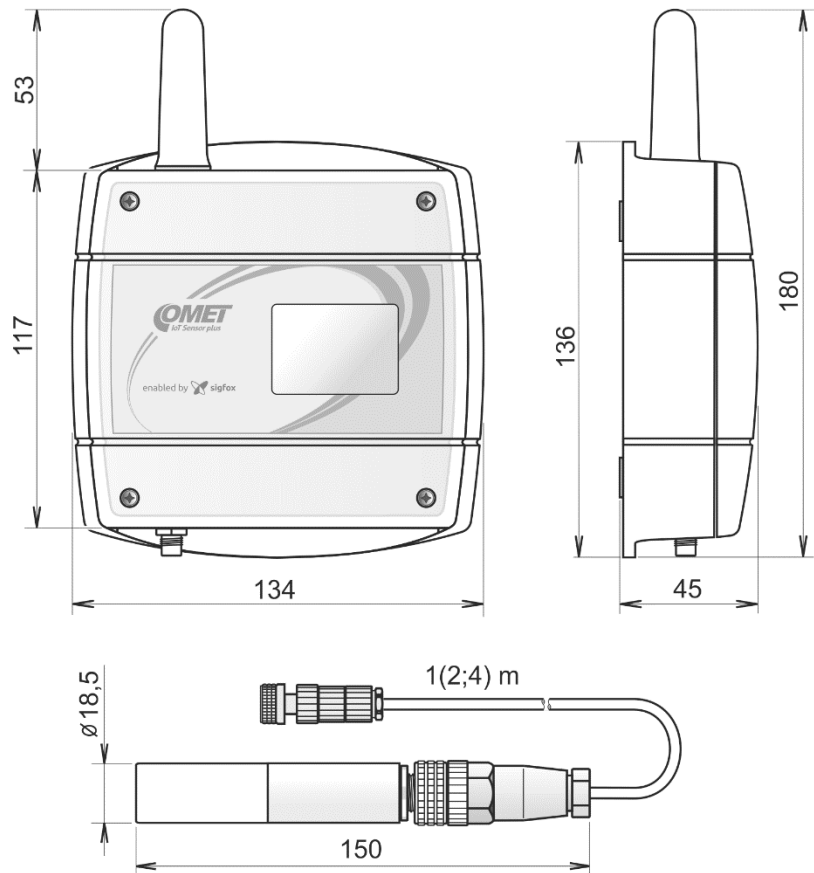

## Declaration of Conformity

The transmitter complies with the requirements of Directive 2014/35 / EU. The original Declaration of Conformity can be found at [www.cometsystem.com](http://www.cometsystem.com).

---

# Appendices

---

## Appendix 1: Connecting the Pt1000/E probe connector (front view of plug, connector M8 ELKA 3008V)

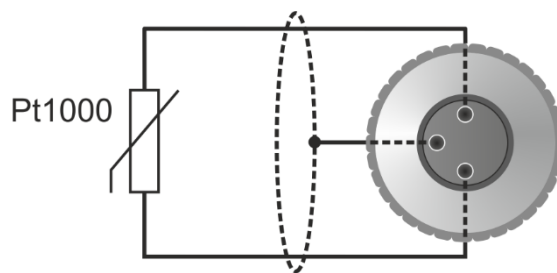

---

## Appendix 2: Connecting the Pt1000/C probe Cinch connector

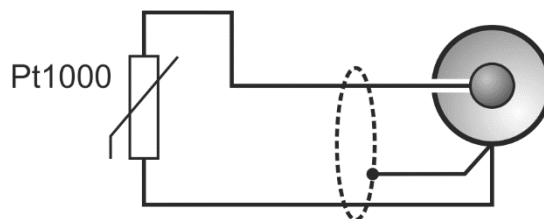

---

## Appendix 3: Accuracy of dewpoint temperature measurement

