

# Wind Direction Smart Sensor (S-WDA-M003)

The Wind Direction smart sensor is designed to work with HOBO® Stations. The smart sensor has a plug-in modular connector that allows it to be added easily to a HOBO Station. All sensor parameters are stored inside the smart sensor, which automatically communicates configuration information to the logger without the need for any programming or extensive setup.



## Inside this Package

- Wind Direction smart sensor with mounting rod

## Specifications

Measurement Range	0 to 355 degrees, 5 degree dead band
Accuracy	± 5 degrees
Resolution	1.4 degrees
Starting Threshold	1 m/s (2.2 mph)
Maximum Wind Speed Survival	60 m/s (134 mph)
Measurement Definition	Unit vector averaging used; vector components for each wind measurement are calculated every three seconds for duration of logging interval (see <i>Measurement Operation</i> )
Operating Temperature Range	-40°C to 70°C (-40°F to 158°F)
Environmental Rating	Weatherproof
Service Life	4 to 6 years typical depending upon environmental conditions
Housing	Injection-molded plastic housing and vane, static dissipating base, lead-free silicon bronze nose and aluminum mounting rod
Bearing Type	Two shielded stainless steel ball bearing
Turning Radius	Approximately 13.5 cm (5.25 in.)
Dimensions	46 x 20 cm (18 x 8.5 in.) including 1.27 cm (0.5 in) diameter mounting rod; 2.5 mm (0.1 in.) drip overhang
Weight	370 g (13 oz)
Bits per Sample	8
Number of Data Channels*	1
Measurement Averaging Option	Automatic averaging (see <i>Measurement Operation</i> )
Cable Length Available	3.5 m (11.5 ft)
Length of Smart Sensor Network Cable*	0.5 m (1.6 ft)
Part Number	S-WDA-M003
	The CE Marking identifies this product as complying with all relevant directives in the European Union (EU).

\* A single HOBO Station logger can accommodate 15 data channels and up to 100 m (325 ft) of smart sensor cable (the digital communications portion of the sensor cables).

## Placement and Mounting Considerations

- The Wind Direction smart sensor should be mounted vertically in a location free of wind shadows.
- For accurate wind direction measurements, mount the sensor at a distance of at least five times the height of the nearest tree, building, or other obstruction.
- Be sure to secure the sensor cable with cable ties to protect it from damage.
- The tripod or mounting mast must be properly grounded. For field installations, you can use Onset's Grounding Kit (M-GKA).

## Wind Direction Smart Sensor

- Secure the mast the wind sensor is mounted on so that it does not vibrate. If you are using Onset masts or tripods, secure them with guy wires.
- The sensor can be damaged with improper handling. Store the sensor in its shipping box until you are ready to install it.
- To minimize measurement errors due to ambient RF, use the shortest possible probe cable length and keep the probe cable as far as possible from other cables carrying high frequency or high-current signals.
- To provide long-term protection from moisture entry, the smart sensor adapter must be mounted horizontally and with the cable wires routed with drip loops so that water drains away from the cable entry point as shown in the example below. When mounted properly, the housing is weatherproof (but not waterproof).

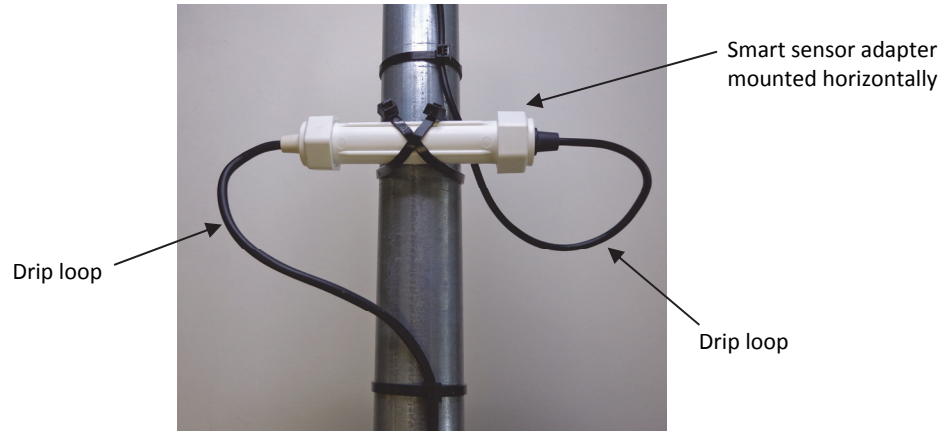

- Refer to the *HOBO Station Tripod Setup Guide* for more details.

## Mounting the Sensor to a Tripod Cross Arm

### Accessories

- Full Cross Arm (M-CAA)
- Half Cross Arm (M-CAB)

### Steps

1. Insert a 1/4-20 x 1 3/4 inch hex head bolt with a flat washer on it through the 1/4 inch hole on the end of the cross arm. Install a lock washer and nut on the bolt. Tighten with a 7/16 inch wrench until snug.
2. Insert the sensor mounting rod into the cross arm allowing the mounting rod to protrude 1.3 cm (1/2 inch) from the bottom of the cross arm.
3. Tighten the nut and bolt until the rod is slightly clamped in place.
4. Adjust the height of the sensor in the cross arm as necessary using one of the following methods and then tighten the nut and bolt until the cross arm just starts to deform.
  - a. Loosen the tri-clamp bolts and raise or lower the entire mast so the sensor is close to the desired height. Make sure there is at least 5 cm (2 inches) of mast extending below the lower tri-clamp.
  - b. Make sure the upper mast dimple is still facing north (if in northern hemisphere) and then re-tighten the tri-clamps. Once the tri-clamp bolts are tight, tighten the lock nuts to lock the bolts in place. This requires two wrenches: one to hold the bolt and one to tighten the lock nut against the tri-clamp.
  - c. Loosen the bolt holding the sensor mounting rod and raise or lower it as necessary to the desired height. Re-tighten the bolt.

## Wind Direction Smart Sensor

5. Use cable ties to secure the sensor cables to the cross arm, bracket, and mast. The sensor cables should run below the cross arm and brackets to minimize the chance of birds pecking and damaging the cables. Cable ties should be spaced no more than 0.3 m (1 foot) apart. Make sure there are drip loops on both sides of the smart sensor housing, which must also be mounted horizontally, as described under *Placement and Mounting Considerations*.

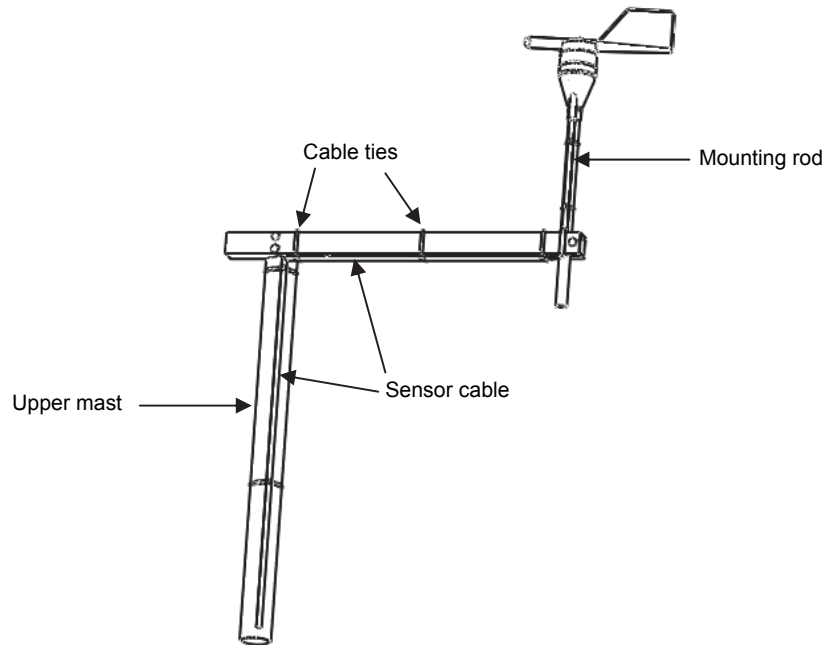

6. Follow the steps in the *North Alignment* section.

### Mounting the Sensor to a Pole

1. Loosely secure the sensor with two hose clamps (not included). Adjust the height as necessary, but make sure the hose clamps are separated by at least 4 inches (10 cm).
2. Secure the sensor cable with cable ties. Make sure there are drip loops on both sides of the smart sensor housing, which must also be mounted horizontally, as described under *Placement and Mounting Considerations*.

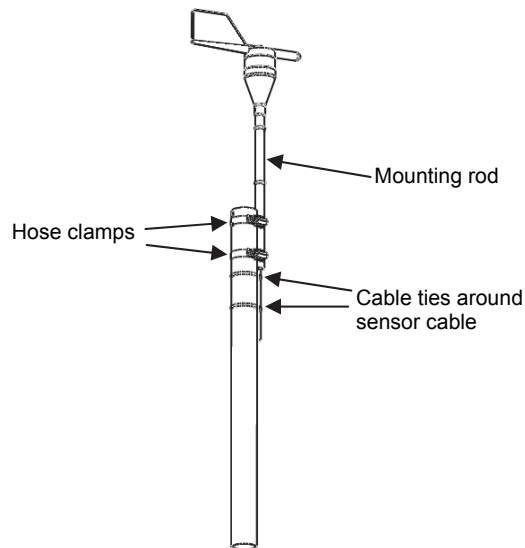

3. Tighten the hose clamps making sure the mounting rod remains vertical.

## Wind Direction Smart Sensor

- Follow the steps in the *North Alignment* section.

### North Alignment

The wind direction sensor must be oriented properly to obtain meaningful data. This involves aligning the north markings on the base of the sensor with true north. There are two methods to align the sensor:

- Compass Alignment
- Global Positioning Satellite (GPS) alignment.

**Note:** The magnetic declination must be known to align the direction sensor to true north using a magnetic compass. Worldwide declination information is available from the National Space Science Data Center at: <http://nssdc.gsfc.nasa.gov/space/cgm/cgm.html>.

### Compass Alignment

Tools required:

- Compass
- Binoculars
- Tape (such as electrical, packing, or duct tape)

Two people are required to complete this procedure.

- Align bronze tip of the wind vane with the north markings on the base.

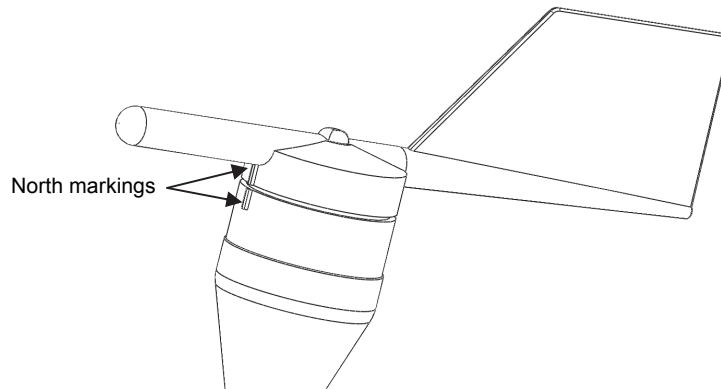

- Secure the base and vane shaft with a piece of tape so that the vane cannot rotate.
- While standing 150 to 200 feet south of the sensor, use the compass to determine magnetic north. If true north is the same as magnetic north, align yourself so the compass points north and directly at the sensor. If you are in area with an east variation, align yourself so that the station is that number of degrees to the east of magnetic north. If you are in an area with a west variation, align yourself so that the station is that number of degrees to the west of magnetic north.
- While viewing the sensor through binoculars, instruct another person to rotate the sensor mounting rod to point the vane north. The vane should seem to disappear from sight when properly aligned.
- Once you've obtained the correct position, secure the mounting rod and remove the tape.

### GPS Alignment

Tools required:

- Handheld GPS with WAAS-enabled receiver or any similar high accuracy GPS device
- Flag, orange cone, or other temporary marker
- Laptop computer with logger software installed

## Wind Direction Smart Sensor

This procedure requires only one person, but is easier to complete with two people. In this procedure, you will be using the GPS receiver first to create an arbitrary waypoint and then to determine the bearing from the sensor to that waypoint. You will then align the sensor so that when the vane is pointed at the waypoint, the direction reported by the logger software matches the GPS receiver's bearing to the waypoint.

1. Connect the sensor to the logger (refer to the *Connecting to the Logger* section below).
2. Connect the laptop to the logger with the PC interface cable.
3. Pick a visible location that is at least 100 meters (110 yards) away from the wind direction sensor and walk to it. Establish a waypoint with the handheld GPS receiver. You may want to use averaging to minimize the waypoint position error if your GPS receiver is so equipped. (For best results, the estimated position error of the waypoint should be less than 10 feet if the distance to the sensor is 100 meters, and less than 20 feet for a distance of 200 meters.) Mark the waypoint with a flag, orange cone, or other suitable marker.
4. Walk back to the sensor and determine the bearing to the waypoint you just created with the GPS receiver. Again you may need to determine the average value of the bearing to keep the errors to a minimum.
5. Start the logger software and select Status to get the current reading (refer to the software manual or online help for details about operating the software).
6. Point the sensor vane directly at the waypoint flag or marker and rotate the sensor mounting rod until the wind direction sensor value in the logger software matches the angle obtained with the GPS receiver.
7. Once the vane is in position, secure the mounting rod and then double-check that the reported angle is correct.

### Connecting to the Logger

To start using the Wind Direction sensor, stop the logger and insert the modular jack into an available port. If a port is not available, use a 1-to-2 adapter (S-ADAPT), which allows you to plug in two sensors into one port. The next time the logger is launched, it will automatically detect the new smart sensor. Note that the HOBO Station supports a maximum of 15 data channels. This sensor requires one channel. Launch the logger and verify the sensor is functioning correctly.

### Measurement Operation

Wind direction measurements are averaged over the logging interval or a 3-second timeframe (whichever is greater). If you set up the sensor to log faster than every 3 seconds, the same sensor reading will be recorded until a new 3-second average is calculated. For example, if the sensor is logging at a 1-second interval, the sensor will report the same wind direction (its calculated average) for three samples before calculating and reporting a new value for another three samples.

### Direction Averaging

Unit vector averaging is used to determine wind direction because traditional averaging would produce inaccurate results. For example, three measurements of 350, 11, and 12 degrees—which are all winds from the north—averaged together would result in 126 degrees, which incorrectly indicates a southeasterly wind. Instead, the vector components (North/South and East/West) for each wind measurement are calculated every three seconds for the duration of the logging interval. At the conclusion of the logging interval, the North/South and East/West components are averaged and then re-combined to calculate the average wind direction for the logging interval.

### Maintenance

The sensor does not normally require any maintenance other than an occasional cleaning. If the vane becomes dirty, rinse the sensor with mild soap and fresh water. Do not immerse the sensor in water or use any organic solvents to clean the unit.

### Verifying Sensor Accuracy

It is recommended that you check the accuracy of the sensor annually. The Wind Direction sensor cannot be calibrated. Onset uses precision components to obtain accurate measurements. If the smart sensor is not providing accurate data, then it is damaged or possibly worn out if it has been in use for several years. If you are unsure of the accuracy, you can send the smart sensor back to Onset for inspection and possible replacement of the mechanism or bearings if required. Contact Onset or your dealer for a Return Merchandise Authorization (RMA) number before sending the sensor.